

VM Series Manual Diaphragm Valves

Product Data Sheet



< STANDARDS >



ASTM D1784
ASTM D1785
ASTM D4101-86
ASTM D3222
ASTM D2467
ASTM D2466
ASTM F441
ASTM F439



ISO 3609
ISO 10931



ANSI B16.5

IPEX VM Series Diaphragm Valves are the ideal solution for modulating flow and controlling dirty or contaminated fluids in a variety of applications. The weir-style design allows for precise throttling while the compact design allows for installation in any orientation. The modular nature of this valve results in many material, body style, and diaphragm options. VM Series Diaphragm Valves are part of our complete systems of pipe, valves, and fittings, engineered and manufactured to our strict quality, performance, and dimensional standards.

VALVE AVAILABILITY

Body Material:	PVC, CPVC, PP, PVDF
Size Range:	3" through 4"
Pressure:	150 psi
Diaphragm:	EPDM, FPM or PTFE (EPDM backed)
Control Style:	Manual Handwheel
End Connections:	Spigot, True Union (Socket), Flanged (ANSI 150)

Sample Specification

1.0 Diaphragm Valves - VM Manual

1.1 Material

- The valve body, including end connectors and unions, shall be made of PVC compound which shall meet or exceed the requirements of cell classification 12454 according to ASTM D1784.
- or The valve body, including end connectors and unions shall be made of Corzan® CPVC compound which shall meet or exceed the requirements of 23447 according to ASTM D1784.
- or The valve body, including end connectors and unions shall be made of stabilized PP homopolymer compound, also containing a RAL 7032 pigment, which shall meet or exceed the requirements of Type I Polypropylene according to ASTM D4101-86.
- or The valve body, including end connectors and unions shall be made of virgin, non-regrind PVDF compound which shall meet or exceed the requirements of Table 1 according to ASTM D3222.
- The valve bonnet assembly shall be made of high temperature, high strength, glass-filled polypropylene.

1.2 Diaphragm

- The diaphragm shall be made of EPDM.
- or The diaphragm shall be made of FPM.
- or The diaphragm shall be made of PTFE (backed with EPDM).

2.0 Connections

2.1 Spigot style

- The IPS spigot PVC end connectors shall conform to the dimensional standard ASTM D1785.
- or The IPS spigot CPVC end connectors shall conform to the dimensional standard ASTM F441.
- or The Metric spigot PP end connectors shall conform to the dimensional standard ISO 3609.
- or The Metric spigot PVDF end connectors shall conform to the dimensional standard ISO 10931.

2.2 Socket style

- The IPS socket PVC end connectors shall conform to the dimensional standards ASTM D2466 and ASTM D2467.
- or The IPS socket CPVC end connectors shall conform to the dimensional standard ASTM F439.

- or The Metric socket PP end connectors shall conform to the dimensional standard ISO 3609.
- or The Metric socket PVDF end connectors shall conform to the dimensional standard ISO 10931.

2.3 Flanged style

- **The ANSI 150 flanged PVC end connectors shall conform to the dimensional standard ANSI B16.5.**
- or The ANSI 150 flanged CPVC end connectors shall conform to the dimensional standard ANSI B16.5.
- or The ANSI 150 flanged PP end connectors shall conform to the dimensional standard ANSI B16.5.
- or The ANSI 150 flanged PVDF end connectors shall conform to the dimensional standard ANSI B16.5.

3.0 Design Features

- All valves shall be weir-style for throttling applications.
- All bodies to be used with EPDM or Viton® diaphragms shall feature raised molded sealing rings (concentric).
- All bodies to be used with PTFE diaphragms shall be machined flat.
- All PTFE diaphragms shall feature a raised molded ring to combine sealing performance and longer life.
- All through bolts shall be made of 304 stainless steel.
- All manual valves shall have a rising position indicator.
- Bodies of all sizes and materials shall have mounting brass inserts.

3.1 Pressure Rating

- All valves shall be rated at 150 psi at 73°F.

3.2 Markings

- All valves shall be marked to indicate size, material designation, and manufacturers name or trade mark.

3.3 Color Coding

- All PVC valves shall be color-coded dark gray.
- or All CPVC valves shall be color-coded light gray.
- or All PP valves shall be color-coded beige gray.
- or All PVDF valves shall not be color-coded and be white in appearance.
- All bonnet assemblies shall be color-coded black.

- 4.0 All valves shall be Xirtec® PVC, Xirtec® CPVC, PP or PVDF by IPEX or approved equal.

VM Series Manual Diaphragm Valves

Product Data Sheet

Valve Selection

Valve Size (inches)	Body Material	Diaphragm Material	IPEX Part Number			Pressure Rating @ 73°F
			Spigot	True Union	ANSI Flanged	
3	PVC	EPDM	054182		054227	150 psi
		FPM	054191		054236	
		PTFE	054200	n/a	054245	
	CPVC	EPDM	054254		054299	
		FPM	054263		054308	
		PTFE	054272		054317	
4	PVC	EPDM	054183		054228	150 psi
		FPM	054192		054237	
		PTFE	054201	n/a	054246	
	CPVC	EPDM	054255		054300	
		FPM	054264		054309	
		PTFE	054273		054318	

Body Material:

- PVC
- CPVC

Size (inches):

- 3
- 4

Diaphragm:

- EPDM
- FPM
- PTFE

End Connections:

- Spigot
- True Union (Socket)
- Flanged (ANSI 150)

IPEX Part Number:

Valve Size (mm)	Body Material	Diaphragm Material	IPEX Part Number		Pressure Rating @ 73°F
			Spigot	True Union	
90	PP	EPDM	054326		150 psi
		FPM	054335		
		PTFE	054344	n/a	
	PVDF	EPDM	054371		
		FPM	054380		
		PTFE	054389		
110	PP	EPDM	054327		150 psi
		FPM	054336		
		PTFE	054345	n/a	
	PVDF	EPDM	054372		
		FPM	054381		
		PTFE	054390		

Body Material:

- PP
- PVDF

Size (inches):

- 90mm
- 110mm

Diaphragm:

- EPDM
- FPM
- PTFE

End Connections:

- Spigot
- True Union (Socket)
- Flanged (ANSI 150)

IPEX Part Number:

VM Series Manual Diaphragm Valves

Product Data Sheet

Dimensions

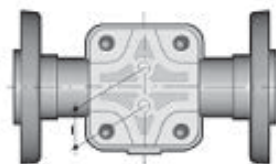
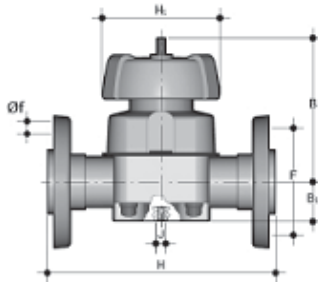
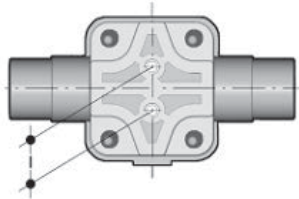
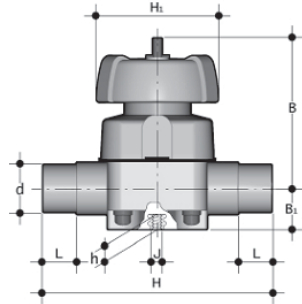

Sizes 3"

Size 4"

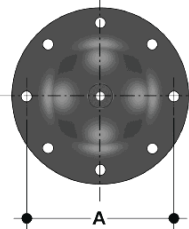
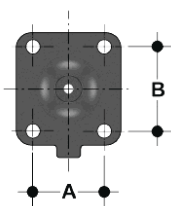

Spigot Connections

Dimension (inches)

Size	PVC / CPVC d (in)	PP / PVDF d (mm)	H	L
3	3.50	90	11.81	2.01
4	4.50	110	13.39	2.40

Dimension (inches)

Size	B ₁	B	H ₁	J	h	l
3	2.17	8.86	8.46	M12	0.91	3.94
4	2.72	11.61	9.84	M12	0.91	4.72

ANSI 150 Flanged (Vanstone) Connections

Dimension (inches)

Size	d	H	B ₁	B	H ₁
3	3.50	11.81	2.17	8.86	8.46
4	4.50	13.39	2.72	11.61	9.84

Dimension (inches)

Size	# holes	f	F	J	h	l
3	4	3/4	6	M12	0.91	3.94
4	4	3/4	7-1/2	M12	0.91	4.72

Diaphragm

Dimension (inches)

Size (inches)	Size (mm)	A	B
3	90	4.49	5.00
4	110	7.60	-

Weights

Approximate Weight (lbs)

Size (inches)	PVC			CPVC			PP		PVDF	
	Spigot	True Union	Flanged	Spigot	True Union	Flanged	Spigot	True Union	Spigot	True Union
3	15.43	n/a	18.60	16.01	n/a	19.33	13.23	n/a	17.15	n/a
4	23.15	n/a	28.34	23.94	n/a	29.39	19.84	n/a	25.65	n/a

VM Series Manual Diaphragm Valves

Product Data Sheet

Pressure – Temperature Ratings

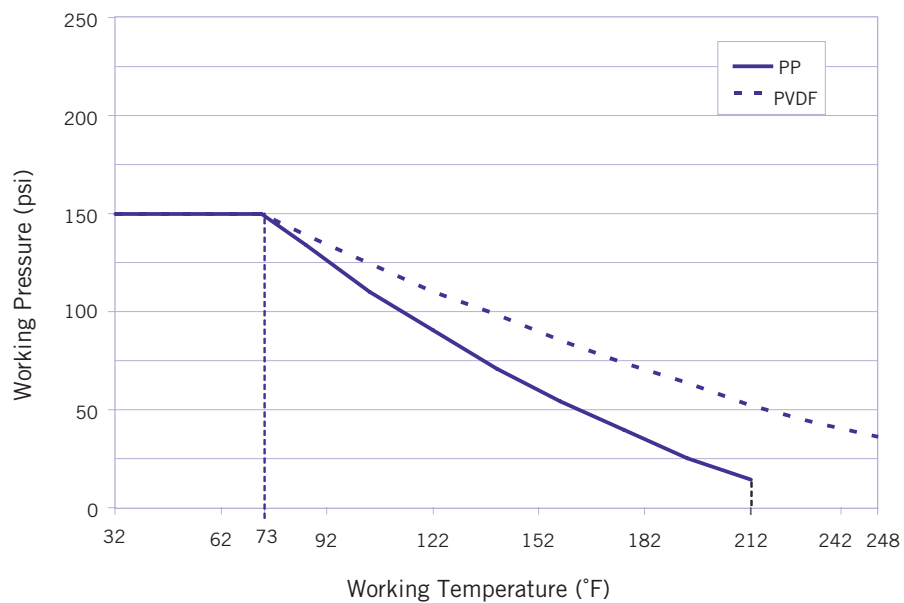
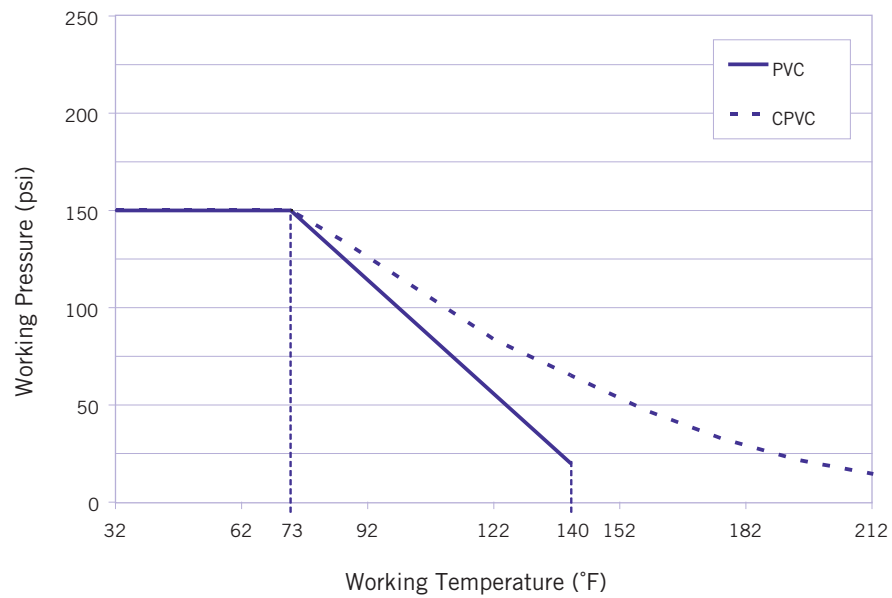

VM Series Manual Diaphragm Valves

Product Data Sheet

Flow Coefficients

Size (in)	C _v
3	140
4	189

Pressure Loss Chart

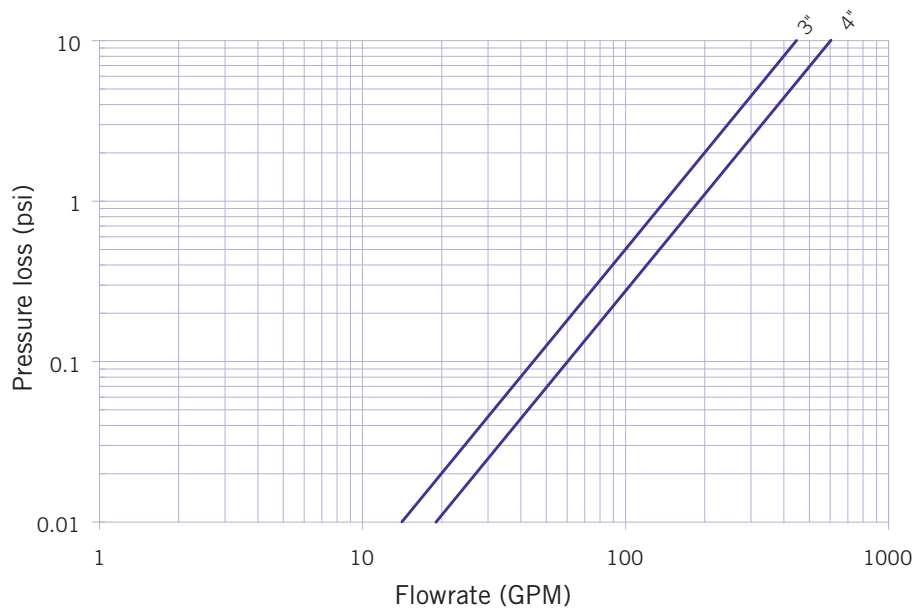

VM Series Manual Diaphragm Valves

Product Data Sheet

Components

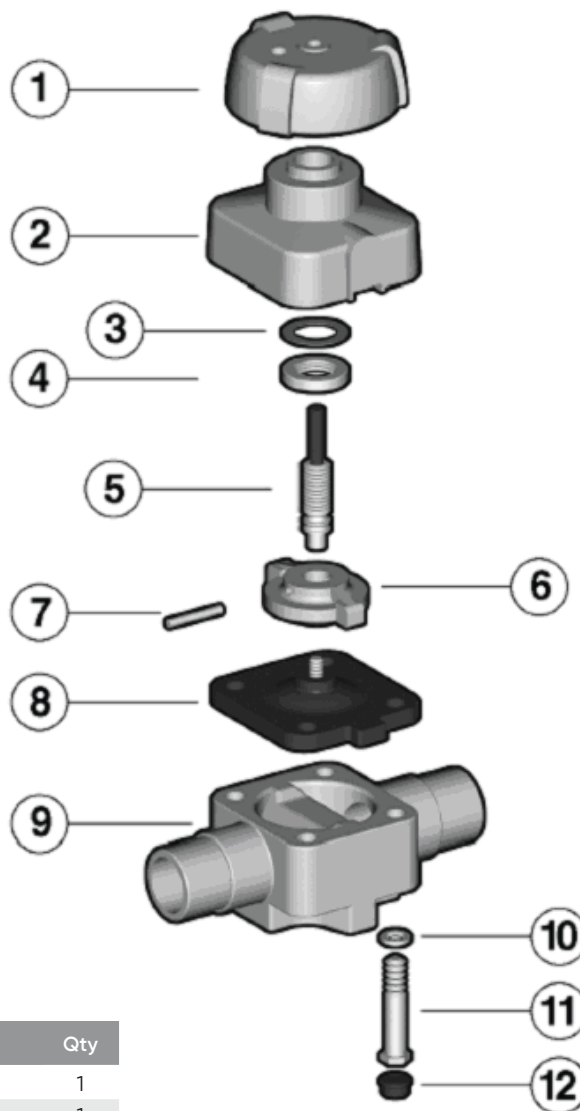

#	Component	Material	Qty
* 1	handwheel	GFPP	1
* 2	bonnet	GFPP	1
* 3	compression bearing	POM	1
* 4	security ring	brass	1
* 5	indicator - stem	SS	1
* 6	compressor	PBT	1
* 7	pin	SS	1
* 8	diaphragm	EPDM / FPM / PTFE	1
* 9	valve body	PVC / CPVC / PP / PVDF	1
* 10	washer	zinc plated steel	4
* 11	hex bolt	zinc plated steel	4
* 12	protective cap	PE	4

* Spare parts available.

Items 1 through 7 are supplied as an assembly.

Contact IPEX for availability of spare components for True Union and Flanged style valves.

Note: Sizes 2-1/2" to 4" have similar components.

Installation Procedures

1. The valve may be installed in any position or direction.
2. Please refer to the appropriate connection style sub-section:
 - a. For spigot style, solvent cement each pipe onto the ends of the valve body. Ensure that excess solvent does not run into the body of the valve.
 - b. For true union style, remove the union nuts and slide them onto the pipe.
 - i. For socket style, solvent cement the end connectors onto the pipe ends. For correct joining procedure, please refer to the section entitled, "Joining Methods – Solvent Cementing" in the IPEX Industrial Technical Manual Series, "Volume I: Vinyl Process Piping Systems". Ensure that excess solvent does not run into the body of the valve. Be sure to allow sufficient cure time before continuing with the valve installation.
 - ii. For threaded style, thread the end connectors onto the pipe ends. For correct joining procedure, please refer to the section entitled, "Joining Methods – Threading" in the IPEX Industrial Technical Manual Series, "Volume I: Vinyl Process Piping Systems".
 - iii. Ensure that the socket o-rings are properly fitted in their grooves then carefully place the valve in the system between the two end connections.
 - iv. Tighten both union nuts. Hand tightening is typically sufficient to maintain a seal for the maximum working pressure. Over-tightening may damage the threads on the valve body and/or the union nut, and may even cause the union nut to crack.
 - c. For flanged style, join both flanges to the pipe flanges. For correct joining procedure, please refer to the section entitled, "Joining Methods – Flanging" in the IPEX Industrial Technical Manual Series, "Volume I: Vinyl Process Piping Systems".
3. If anchoring is required, fix the valve to the supporting structure using the mounting holes on the bottom of the valve body.

Disassembly

1. If removing the valve from an operating system, isolate the valve from the rest of the line. Be sure to depressurize and drain the valve and isolated branch.
2. If necessary, detach the valve from the support structure by disassembling the threaded connections on the bottom of the valve body (9).
3. Please refer to the appropriate connection style sub-section:
 - a. For spigot style, cut the pipe on either side of the valve and remove from the line.
 - b. For true union connections, loosen both union nuts and drop the valve out of the line. If retaining the socket o-rings, take care that they are not lost when removing the valve from the line.
 - c. For flanged style, loosen each bolt holding the valve to the pipe flanges. Please refer to the section entitled, "Joining Methods – Flanging" in the IPEX Industrial Technical Manual Series, "Volume I: Vinyl Process Piping Systems" for a recommended bolt tightening pattern diagram. Follow the same pattern when disassembling the flanged joints then carefully remove the valve from the line.
4. Remove the protective caps (12), then loosen and remove the bolts (11) and washers (10) from the bottom of the valve body.
5. Loosen and remove the diaphragm (8) from the compressor (6).
6. Rotate the handwheel (1) clockwise until the stem-compressor assembly (5, 6, 7) is released.
7. The valve components can now be checked for problems and/or replaced.

Note: It is not recommended to attempt to further disassemble the handwheel/bonnet assembly as it may cause irreversible damage to the components.

Assembly

Note: Before assembling the valve components, it is advisable to lubricate the o-rings with a water soluble lubricant. **Be sure to consult the "IPEX Chemical Resistance Guide" and/or other trusted resources to determine specific lubricant-rubber compatibilities.**

1. Insert the stem-compressor assembly into the bonnet and tighten by threading in a counterclockwise (left-hand thread) direction. The guide tabs on the compressor must be lined up with the bonnet grooves before cycling the handwheel to further retract the compressor.
2. Insert the diaphragm into the compressor and turn in a clockwise direction until sufficiently tight. Ensure that the tab lines up with the notched side of the bonnet then cycle the handwheel counterclockwise until the diaphragm is fully retracted.
3. Place the bonnet and diaphragm onto the valve body taking care to properly line up the sealing surfaces.
4. Insert the bolts and washers and tighten in an even (cross-like) pattern.
5. Replace the protective caps on the bolt heads.

Assembly

The purpose of system testing is to assess the quality of all joints and fittings to ensure that they will withstand the design working pressure, plus a safety margin, without loss of pressure or fluid. Typically, the system will be tested and assessed in sub-sections as this allows for improved isolation and remediation of potential problems. With this in mind, the testing of a specific installed valve is achieved while carrying out a test of the overall system.

An onsite pressure test procedure is outlined in the IPEX Industrial Technical Manual Series, "Volume I: Vinyl Process Piping Systems" under the section entitled, "Testing". The use of this procedure should be sufficient to assess the quality of a valve installation. **In any test or operating condition, it is important to never exceed the pressure rating of the lowest rated appurtenance in the system.**

Important points:

- Never test thermoplastic piping systems with compressed air or other gases including air-over-water boosters.
- When testing, do not exceed the rated maximum operating pressure of the valve.
- Avoid the rapid closure of valves to eliminate the possibility of water hammer which may cause damage to the pipeline or the valve.

Please contact IPEX customer service and technical support with regard to any concern not addressed in this data sheet or the technical manual.

About the IPEX Group of Companies

As leading suppliers of thermoplastic piping systems, the IPEX Group of Companies provides our customers with some of the world's largest and most comprehensive product lines. All IPEX products are backed by more than 50 years of experience. With state-of-the-art manufacturing facilities and distribution centers across North America, we have established a reputation for product innovation, quality, end-user focus and performance.

Markets served by IPEX group products are:

- Electrical systems
- Telecommunications and utility piping systems
- Industrial process piping systems
- Municipal pressure and gravity piping systems
- Plumbing and mechanical piping systems
- Electrofusion systems for gas and water
- Industrial, plumbing and electrical cements
- Irrigation systems
- PVC, CPVC, PP, PVDF, PE, ABS, and PEX pipe and fittings

Xirtec® is a registered trademark of IPEX Branding Inc. Xirtec® CPVC piping systems are made with Corzan® CPVC compounds. Corzan® is a registered trademark of the Lubrizol Corporation.

This literature is published in good faith and is believed to be reliable. However, it does not represent and/or warrant in any manner the information and suggestions contained in this brochure. Data presented is the result of laboratory tests and field experience.

A policy of ongoing product improvement is maintained. This may result in modifications of features and/or specifications without notice.