

## Friatec® DAA High Pressure Tapping Tee

The DAA High Pressure Tapping Tee is the leading choice among engineers and contractors because of its easy assembly and high quality design for the gas and water industry.

With IPEX's portable Genesis F3 universal electrofusion processor, all IPEX tapping tee barcode labels can be scanned to allow for easy traceability of fusion conditions and records.

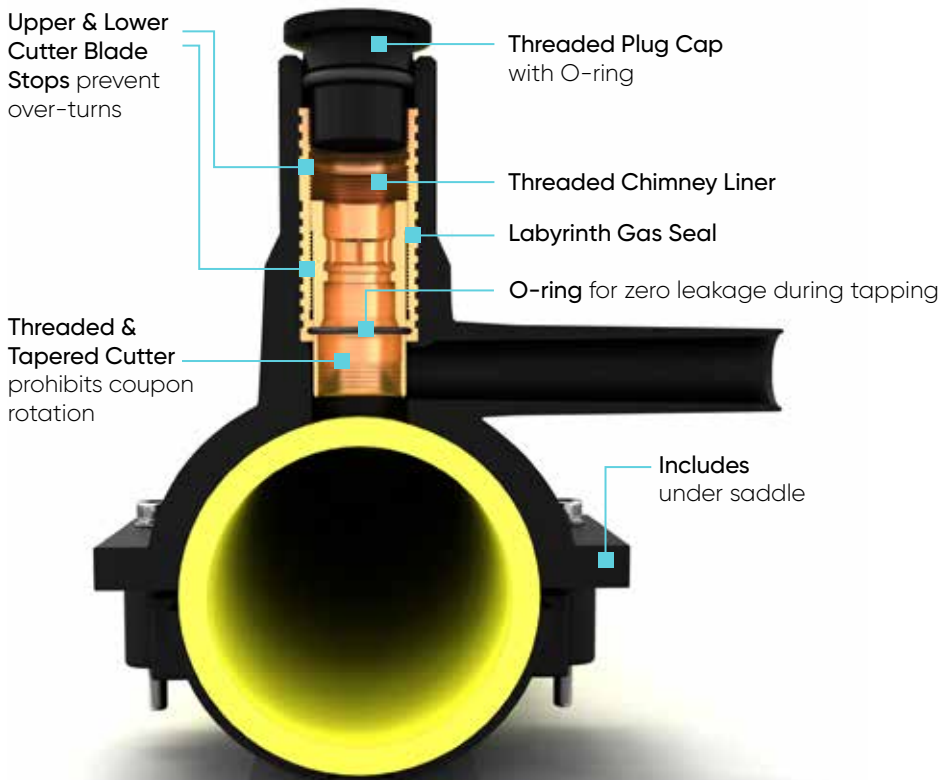

### Features:

- Corrosion-proof construction
- Easy to assemble – no rounding clamps or special tools are required
- Cutter and sleeve made of brass, allowing for easy cutting of thick wall pipe
- Lower and upper “cutter stops” prevent overcutting, as well as accidental removal of cutter
- High Pressure  
gas: 125 psi, water: 200 psi

### Standards:

NSF-61 ASTM D2513



### Contact us

Visit our website: [ipexna.com](http://ipexna.com)

Toll free Canada: (866) 473-9462

Friatec® is manufactured by FRIATEC AG.  
Friatec® is a trademark of FRIATEC AG.

# DAA High Pressure Tapping Tees

## DAA High Pressure Tapping Tees – IPS

Nominal Pipe OD IPS	Nominal Outlet	Product Code	ID	OD 1	OD 2	Cutter	L	Z1	Z2	B
2"	1/2" CTS	228042	2.378	0.626	1.575	0.846	3.878	1.780	3.937	4.094
2"	3/4" IPS	228029	2.378	1.051	1.575	0.846	3.878	1.780	3.701	4.094
2"	1" CTS	228033	2.378	1.126	1.575	0.846	3.860	1.780	3.701	4.094
2"	1" IPS	228032	2.378	1.315	1.575	0.846	3.860	1.780	3.701	4.094
2"	2" IPS	228274	2.378	2.378	1.575	1.180	5.000	2.170	5.952	6.060
3"	1/2" CTS	228043	3.504	0.626	1.969	1.180	4.764	2.343	4.410	4.803
3"	3/4" IPS	228030	3.504	1.051	1.969	1.180	4.764	2.343	3.937	4.803
3"	1" CTS	228031	3.504	1.126	1.969	1.180	4.764	2.343	4.255	4.803
3"	1" IPS	228044	3.504	1.315	1.969	1.180	4.764	2.343	4.255	4.803
3"	2" IPS	228028	3.504	2.378	1.969	1.180	4.780	2.350	6.890	5.905
4"	1/2" CTS	228045	4.512	0.626	1.969	1.180	4.764	2.905	4.016	4.785
4"	3/4" IPS	228034	4.512	1.051	1.969	1.180	4.764	2.846	4.409	4.764
4"	1" CTS	228035	4.512	1.126	1.969	1.180	4.764	2.846	4.527	4.785
4"	1" IPS	228046	4.512	1.315	1.969	1.180	4.764	2.913	4.527	4.785
4"	2" IPS	228025	4.512	2.378	1.969	1.180	4.780	2.913	7.086	4.905
6"	1/2" CTS	228047	6.638	0.626	1.969	1.180	6.575	4.500	4.586	7.677
6"	3/4" IPS	228036	6.638	1.051	1.969	1.180	6.575	4.528	4.331	7.677
6"	1" CTS	228038	6.638	1.126	1.969	1.180	6.575	4.528	4.331	7.677
6"	1" IPS	228049	6.638	1.315	1.969	1.180	6.575	4.528	4.331	7.677
6"	2" IPS	228027	6.638	2.378	1.969	1.180	6.575	4.803	6.811	7.677
8"	1/2" CTS	228048	8.605	0.626	1.969	1.180	6.575	5.483	4.586	7.677
8"	3/4" IPS	228037	8.605	1.051	1.969	1.180	6.575	5.315	4.331	7.677
8"	1" CTS	228041	8.605	1.126	1.969	1.180	6.575	5.315	4.331	7.677
8"	1" IPS	228040	8.605	1.315	1.969	1.180	6.575	5.315	4.331	7.677
8"	2" IPS	228039	8.605	2.378	1.969	1.180	6.575	5.827	6.811	7.677
* 10" – 16"	2" IPS	228056	10.75 – 16.00	–	1.969	1.180	6.575	–	7.087	7.677
❖ 10" – 16"	2" IPS	128246	10.75 – 16.00	–	1.969	1.180	6.575	–	7.087	7.677

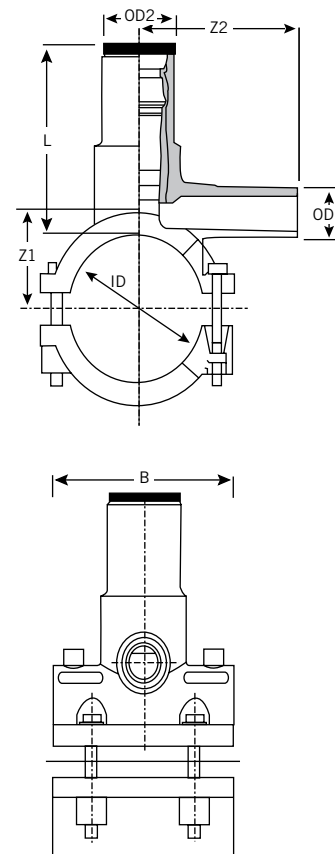

\* Friatop pneumatic top-loading tool #228053 required

❖ Extended cutter 10" x 16" x 2" DAA can make a full coupon cut on 16" IPS SDR 11 Pipe

## Total Elapsed Cooling Times in Minutes

Nominal Size	Before Pressurizing via Outlet	Before Tapping
1-1/4" IPS	15	20
2" IPS	15	20
3" – 4" IPS & DIPS	20	30
6" IPS & DIPS	30	45
8" IPS & DIPS	50	60
10" – 14" IPS & DIPS	50	60
16" – 20" IPS & DIPS	50	60

FRIATEC Safety Fittings can be fused to all PE pipes SDR Range 11 through 17.6.

Allow electrofusion joints to cool prior to handling, pressurizing or tapping.

For 12" and 14" IPS applications, maximum SDR for full coupon cut is SDR 11.

\* Part number 228056 for 16" IPS applications, maximum SDR for full coupon cut is SDR 13.5.

For 12" DIP applications, maximum SDR for full coupon cut is SDR 11.

For 14" and 16" DIP applications, maximum SDR for full coupon cut is SDR 17.