

DK Series Manual Diaphragm Valves

Find us in
MasterSpec[®]
a product of The American Institute of Architects

Submittal Data Sheet



Job or Customer:

Engineer:

Contractor:

Submitted by: Date

Approved by: Date

Order No: Date

Specification:

< STANDARDS >



ASTM D1784
ASTM D1785
ASTM D4101
ASTM D3222
ASTM D2464
ASTM D2467
ASTM D2466
ASTM F441
ASTM F437
ASTM F439
ASTM F1498



ISO 3609
ISO 10931



ANSI B16.5

IPEX DK Series Dialock[®] Diaphragm Valves are the ideal solution for modulating flow and controlling dirty or abrasive fluids in a variety of applications. The modular nature of these valves results in many material, body style, and diaphragm options. The re-designed weir-style body has significantly improved the DK's flow rate compared to the old design and it facilitates precise linear flow regulation through the valve's full range of operation. The new innovative and patented Dialock locking mechanism allows the manual handwheel to be adjusted and locked in over 300 positions.

VALVE AVAILABILITY

Body Material:	PVC, CPVC, PP, PVDF
Size Range:	1/2" t hrough 2-1/2"
Pressure:	150 psi
Diaphragm:	EPDM, FPM or PTFE (EPDM backed)
Control Style:	Manual Handwheel
End Connections:	Spigot, True Union (Socket, Threaded) Flanged (ANSI 150)

ipexna.com
Toll Free: 800 463-9572



DK Series Manual Diaphragm Valves

Submittal Data Sheet

Sample Specification

1.0 Diaphragm Valves – DK Manual

1.1 Material

- The valve body, including end connectors and unions, shall be made of PVC compound which shall meet or exceed the requirements of cell classification 12454 according to ASTM D1784.
- or The valve body, including end connectors and unions, shall be made of Corzan® CPVC compound which shall meet or exceed the requirements of cell classification 23447 according to ASTM D1784.
- or The valve body, including end connectors and unions, shall be made of stabilized PP homopolymer compound, also containing a RAL 7032 pigment, which shall meet or exceed the requirements of Type I Polypropylene according to ASTM D4101.
- or The valve body, including end connectors and unions, shall be made of virgin, non-regrind PVDF compound which shall meet or exceed the requirements of Table 1 according to ASTM D3222.
- The valve bonnet assembly shall be made of high temperature, high strength, glass-filled polypropylene (GFPP).

1.2 Diaphragm

- The diaphragm shall be made of EPDM.
- or The diaphragm shall be made of FKM.
- or The diaphragm shall be made of PTFE (backed with EPDM).

2.0 Connections

2.1 Spigot Style

- The IPS spigot PVC end connectors shall conform to the dimensional standard ASTM D1785.
- or The IPS spigot CPVC end connectors shall conform to the dimensional standard ASTM F441.
- or The Metric spigot PP end connectors shall conform to the dimensional standard ISO 3609.
- or The Metric spigot PVDF end connectors shall conform to the dimensional standard ISO 10931.

2.2 Socket Style

- The IPS socket PVC end connectors shall conform to the dimensional standards ASTM D2466 and ASTM D2467.
- or The IPS socket CPVC end connectors shall conform to the dimensional standard ASTM F439.
- or The Metric socket PP end connectors shall conform to the dimensional standard ISO 3609.
- or The Metric socket PVDF end connectors shall conform to the dimensional standard ISO 10931.

2.3 Threaded Style

- The female NPT threaded PVC end connectors shall conform to the dimensional standards ASTM D2464, ASTM F1498, and ANSI B1.20.1.
- or The female NPT threaded CPVC end connectors shall conform to the dimensional standards ASTM F437, ASTM F1498, and ANSI B1.20.1.

2.4 Flanged Style

- The ANSI 150 flanged PVC end connectors shall conform to the dimensional standard ANSI B16.5.
- or The ANSI 150 flanged CPVC end connectors shall conform to the dimensional standard ANSI B16.5.
- or The ANSI 150 flanged PP end connectors shall conform to the dimensional standard ANSI B16.5.
- or The ANSI 150 flanged PVDF end connectors shall conform to the dimensional standard ANSI B16.5.

3.0 Design Features

- All valves shall be weir-style for throttling applications.
- All valves shall have a manual handwheel that can be adjusted and locked in over 300 positions.
- The manual handwheel shall be made of high strength glass-filled polypropylene (GFPP).
- All valves shall have a graduated optical position indicator to allow for a visual check of the valve position.
- All valves shall have a custom labelling plate housed in a transparent cap.
- All through bolts shall be made of stainless steel.
- The valve shall incorporate a feature that allows an identification tag to be easily affixed to the valve body.
- Bodies of PVC, CPVC and PP valves shall have brass mounting inserts.
- Bodies of PVDF valves shall have stainless steel mounting inserts.

DK Series Manual Diaphragm Valves

Submittal Data Sheet

3.1 Pressure Rating

- All valves shall be rated at 150 psi at 73°F.

3.2 Markings

- All valves shall be marked to indicate size, material designation, and manufacturers name or trade mark.

3.3 Colour Coding

- All PVC valves shall be colour-coded dark gray.
- or All CPVC valves shall be colour-coded light gray.
- or All PP valves shall be colour-coded beige gray.
- or All PVDF valves shall not be colour-coded and be white in appearance.
- All bonnet assemblies shall be colour-coded black.

- 4.0** All valves shall be Xirtec® PVC, Xirtec® CPVC, PP or PVDF by IPEX or approved equal.

DK Series Manual Diaphragm Valves

Submittal Data Sheet

Valve Selection

Valve Size (inches)	Body Material	Diaphragm Material	IPEX Part Number				Pressure Rating @ 73°F
			IPS Spigot	IPS Socket	FNPT Threaded	ANSI 150 Flanged	
1/2	PVC	EPDM	354175	354202	354004	354220	150 psi
		FPM	354184	354214	354016	354229	
		PTFE	354193	354208	354010	354238	
	CPVC	EPDM	354247	354274	354022	354292	
		FPM	354256	354280	354028	354301	
		PTFE	354265	354286	354034	354310	
3/4	PVC	EPDM	354176	354203	354005	354221	
		FPM	354185	354215	354017	354230	
		PTFE	354194	354209	354011	354239	
	CPVC	EPDM	354248	354275	354023	354293	
		FPM	354257	354281	354029	354302	
		PTFE	354266	354287	354035	354311	
1	PVC	EPDM	354177	354204	354006	354222	
		FPM	354186	354216	354018	354231	
		PTFE	354195	354210	354012	354240	
	CPVC	EPDM	354249	354276	354024	354294	
		FPM	354258	354282	354030	354303	
		PTFE	354267	354288	354036	354312	
1-1/4	PVC	EPDM	354178	354205	354007	354223	
		FPM	354187	354217	354019	354232	
		PTFE	354196	354211	354013	354241	
	CPVC	EPDM	354250	354277	354025	354295	
		FPM	354259	354283	354031	354304	
		PTFE	354268	354289	354037	354313	
1-1/2	PVC	EPDM	354179	354206	354008	354224	
		FPM	354188	354218	354020	354233	
		PTFE	354197	354212	354014	354242	
	CPVC	EPDM	354251	354278	354026	354296	
		FPM	354260	354284	354032	354305	
		PTFE	354269	354290	354038	354314	
2	PVC	EPDM	354180	354207	354009	354225	
		FPM	354189	354219	354021	354234	
		PTFE	354198	354213	354015	354243	
	CPVC	EPDM	354252	354279	354027	354297	
		FPM	354261	354285	354033	354306	
		PTFE	354270	354291	354039	354315	
2-1/2	PVC	EPDM	354181	-	-	354226	
		FPM	354190	-	-	354235	
		PTFE	354199	-	-	354244	
	CPVC	EPDM	354253	-	-	354298	
		FPM	354262	-	-	354307	
		PTFE	354271	-	-	354316	

Body Material:

- PVC
- CPVC

Size (inches):

- 1/2
- 3/4
- 1
- 1-1/4
- 1-1/2
- 2
- 2-1/2

Diaphragm:

- EPDM
- FPM
- PTFE (EPDM Backed)

End Connections:

- Spigot (IPS)
- True Union (IPS Socket)
- True Union (FNPT Threaded)
- Flanged (ANSI 150)

IPEX Part Number:

DK Series Manual Diaphragm Valves

Submittal Data Sheet

Valve Selection, continued

Valve Size (mm)	Body Material	Diaphragm Material	IPEX Part Number		Pressure Rating @ 73°F
			True Union		
			Metric Spigot	Metric Socket	
20	PP	EPDM	354219	354346	150 psi
		FPM	354328	354352	
		PTFE	354337	354358	
	PVDF	EPDM	354364	354391	
		FPM	354373	354397	
		PTFE	354382	354403	
25	PP	EPDM	354220	354347	
		FPM	354329	354353	
		PTFE	354338	354359	
	PVDF	EPDM	354365	354392	
		FPM	354374	354398	
		PTFE	354383	354405	
32	PP	EPDM	354221	354348	
		FPM	354330	354354	
		PTFE	354339	354360	
	PVDF	EPDM	354366	354393	
		FPM	354375	354399	
		PTFE	354384	354406	
40	PP	EPDM	354222	354349	
		FPM	354331	354355	
		PTFE	354340	354361	
	PVDF	EPDM	354367	354394	
		FPM	354376	354400	
		PTFE	354385	354407	
50	PP	EPDM	354223	354350	
		FPM	354332	354356	
		PTFE	354341	354362	
	PVDF	EPDM	354368	354395	
		FPM	354377	354401	
		PTFE	354386	354408	
63	PP	EPDM	354224	354351	
		FPM	354333	354357	
		PTFE	354342	354363	
	PVDF	EPDM	354369	354396	
		FPM	354378	354402	
		PTFE	354387	354409	
75	PP	EPDM	354225	-	
		FPM	354334	-	
		PTFE	354343	-	
	PVDF	EPDM	354370	-	
		FPM	354379	-	
		PTFE	354388	-	

Body Material:

- PP
- PVDF

Size (inches):

- 20mm
- 25mm
- 32mm
- 40mm
- 50mm
- 63mm
- 75mm

Diaphragm:

- EPDM
- FPM
- PTFE (EPDM Backed)

End Connections:

- Spigot (Metric)
- True Union (Metric Socket)

IPEX Part Number:

DK Series Manual Diaphragm Valves

Submittal Data Sheet

Dimensions

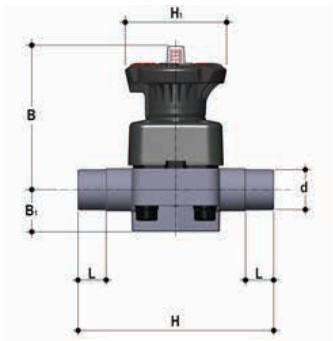

IPS Spigot Connections

Dimension (inches)

Size	d(in) PVC/CPVC	d(mm) PP/PVDF	B	B ₁	H	H ₁	L
1/2	0.84	20	4.02	0.98	4.88	3.15	0.63
3/4	1.05	25	4.13	1.18	5.67	3.15	0.75
1	1.32	32	4.49	1.30	6.06	3.15	0.87
1-1/4	1.66	40	4.69	1.18	6.85	3.15	1.02
1-1/2	1.90	50	5.79	1.38	7.64	4.72	1.22
2	2.38	63	6.77	1.81	8.82	4.72	1.50
2-1/2	2.88	75	6.77	1.81	11.18	4.72	1.73

IPS Socket Connections

Dimension (inches)

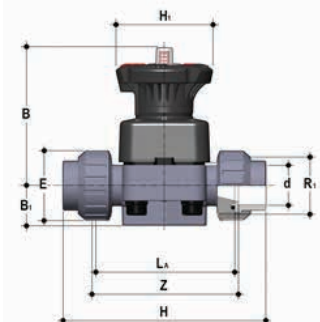

Size	d(in) PVC/CPVC	d(mm) PP/PVDF	B	B ₁	E	H PVC/CPVC	H PP/PVDF	H ₁	L ₁	R ₁	Z PVC/CPVC	Z PP/PVDF
1/2	0.84	20	4.02	0.98	1.61	5.63	5.08	3.15	3.54	1	3.86	3.94
3/4	1.05	25	4.13	1.18	1.97	6.57	6.06	3.15	4.25	1-1/4	4.53	4.57
1	1.32	32	4.49	1.30	2.28	7.09	6.61	3.15	4.57	1-1/2	4.80	4.88
1-1/4	1.66	40	4.69	1.18	2.83	8.19	7.56	3.15	5.28	2	5.67	5.51
1-1/2	1.90	50	5.79	1.38	3.11	9.21	8.74	4.72	6.06	1-1/4	6.46	6.30
2	2.38	63	6.77	1.81	3.86	10.71	10.47	4.72	7.24	2-3/4	7.68	7.48

FNPT Threaded Connections

Dimension (inches)

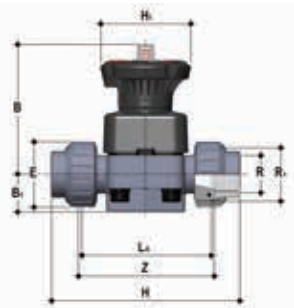

R	B	B ₁	E	H	H ₁	L ₁	R ₁	Z
1/2	4.02	0.98	1.61	5.16	3.15	3.54	1	3.82
3/4	4.13	1.18	1.97	5.94	3.15	4.25	1-1/4	4.65
1	4.49	1.30	2.28	6.50	3.15	4.57	1-1/2	5.00
1-1/4	4.69	1.18	2.83	7.40	3.15	5.28	2	5.71
1-1/2	5.79	1.38	3.11	8.19	4.72	6.06	2-1/4	6.50
2	6.77	1.81	3.86	9.69	4.72	7.24	2-3/4	7.68

Dimension (inches)

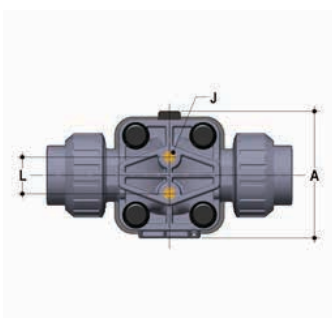

Size	A	L	J
1/2	2.91	0.98	M6 x 10
3/4	2.91	0.98	M6 x 10
1	3.43	0.98	M6 x 10
1-1/4	3.43	0.98	M6 x 10
1-1/2	4.49	1.75	M8 x 14
2	5.35	1.75	M8 x 14
2-1/2	5.35	1.75	M8 x 14

DK Series Manual Diaphragm Valves

Submittal Data Sheet

Dimensions

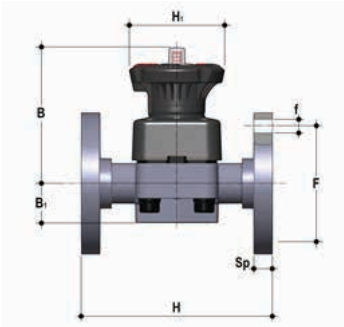

ANSI 150 Flanged (Vanstone) Connections

Size	Dimension (inches)						
	B	B ₁	f	H	H ₁	Sp	# holes
1/2	4.02	0.98	5/8	4.25	3.15	0.53	4
3/4	4.13	1.18	5/8	5.91	3.15	0.53	4
1	4.49	1.30	5/8	6.30	3.15	0.55	4
1-1/4	4.69	1.18	5/8	7.09	3.15	0.55	4
1-1/2	5.79	1.38	5/8	7.87	4.72	0.63	4
2	6.77	1.81	3/4	9.06	4.72	0.63	4
2-1/2	6.77	1.81	3/4	11.42	4.72	0.83	4

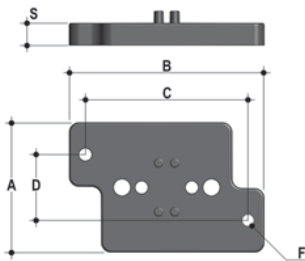

Wall/Panel Mounting Plate

Size	Dimension (inches)					
	A	B	C	D	F	S
1/2	2.56	3.82	3.19	1.30	0.22	0.43
3/4	2.56	3.82	3.19	1.30	0.22	0.43
1	2.56	3.82	3.19	1.30	0.22	0.43
1-1/4	2.56	3.82	3.19	1.30	0.22	0.43
1-1/2	2.56	5.67	5.12	1.30	0.26	0.43
2	2.56	5.67	5.12	1.30	0.26	0.43
2-1/2	2.56	5.67	5.12	1.30	0.26	0.43

Diaphragm

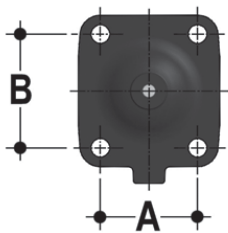

Size (in)	Dimension (inches)		
	Size (mm)	A	B
1/2	20	1.57	1.73
3/4	25	1.57	1.73
1	32	1.81	2.13
1-1/4	40	1.81	2.13
1-1/2	50	2.56	2.76
2	63	3.07	3.23
2-1/2	75	3.07	3.23

Approximate Weight (lbs)

Size	PVC			CPVC			PP		PVDF	
	Spigot	True Union	Flanged	Spigot	True Union	Flanged	Spigot	True Union	Spigot	True Union
1/2	1.01	1.10	1.47	1.01	1.10	1.47	0.95	1.01	1.10	1.21
3/4	1.06	1.24	1.50	1.06	1.24	1.50	0.98	1.10	1.16	1.40
1	1.50	1.74	2.14	1.50	1.74	2.14	1.37	1.53	1.67	2.00
1-1/4	1.60	2.02	2.61	1.60	2.02	2.61	1.43	1.72	1.80	2.37
1-1/2	3.36	3.83	4.63	3.36	3.83	4.63	3.04	3.36	3.75	4.38
2	5.27	6.14	6.96	5.27	6.14	6.96	4.71	5.31	5.94	7.13
2-1/2	5.55	-	7.98	5.55	-	7.98	4.91	-	6.33	-

DK Series Manual Diaphragm Valves

Submittal Data Sheet

Pressure – Temperature Ratings

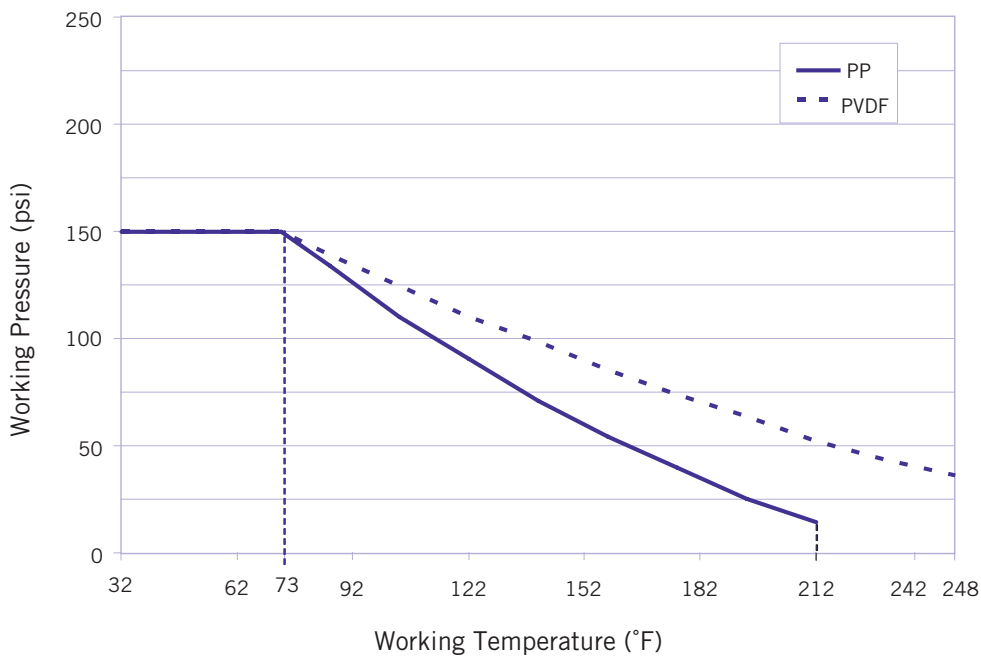
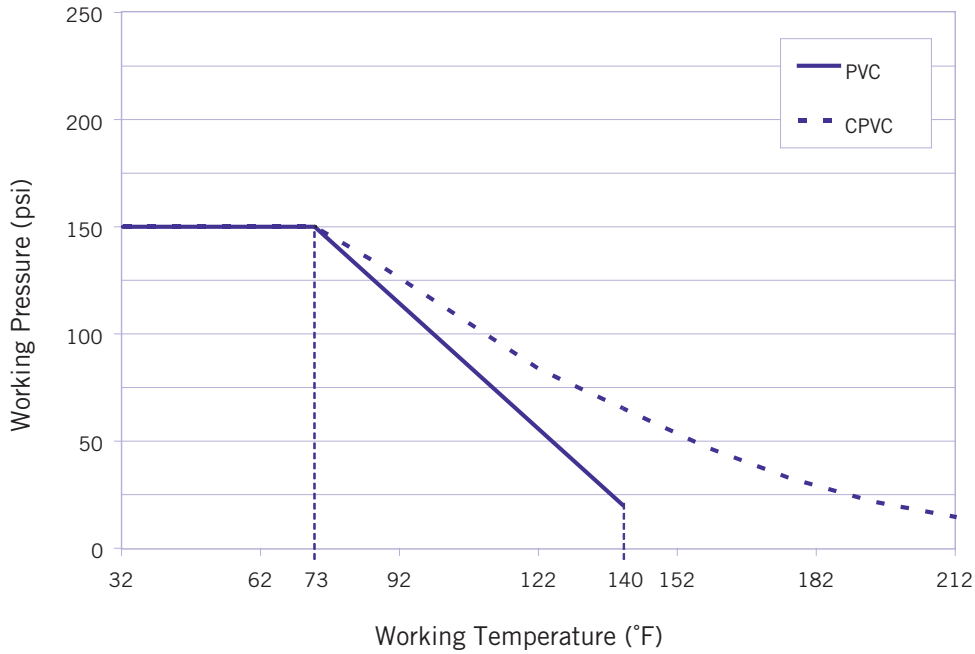

DK Series Manual Diaphragm Valves

Submittal Data Sheet

Flow Coefficients

Size (in)	C _v
1/2	7.8
3/4	18.1
1	30.8
1-1/4	38.1
1-1/2	75.3
2	114.2
2-1/2	110.9

Pressure Loss Chart

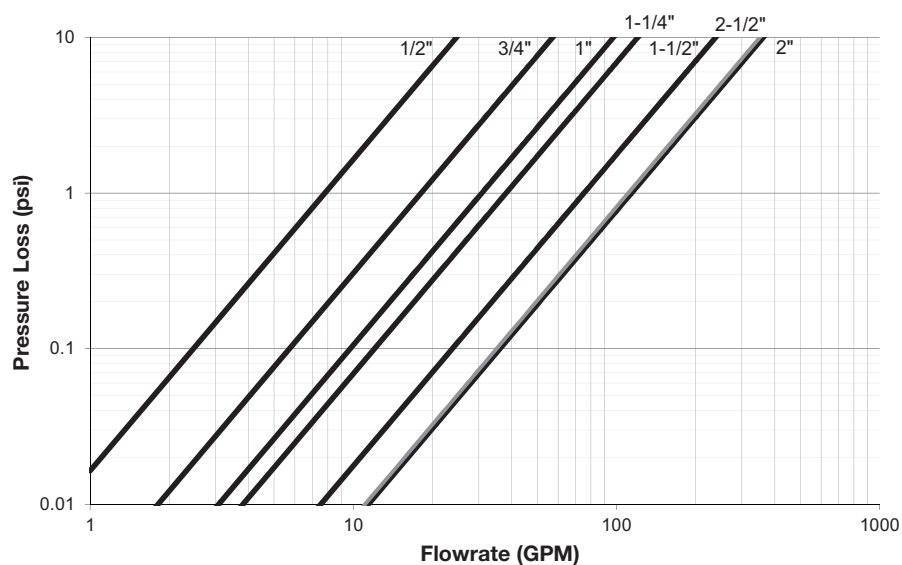

DK Series Manual Diaphragm Valves

Submittal Data Sheet

Components

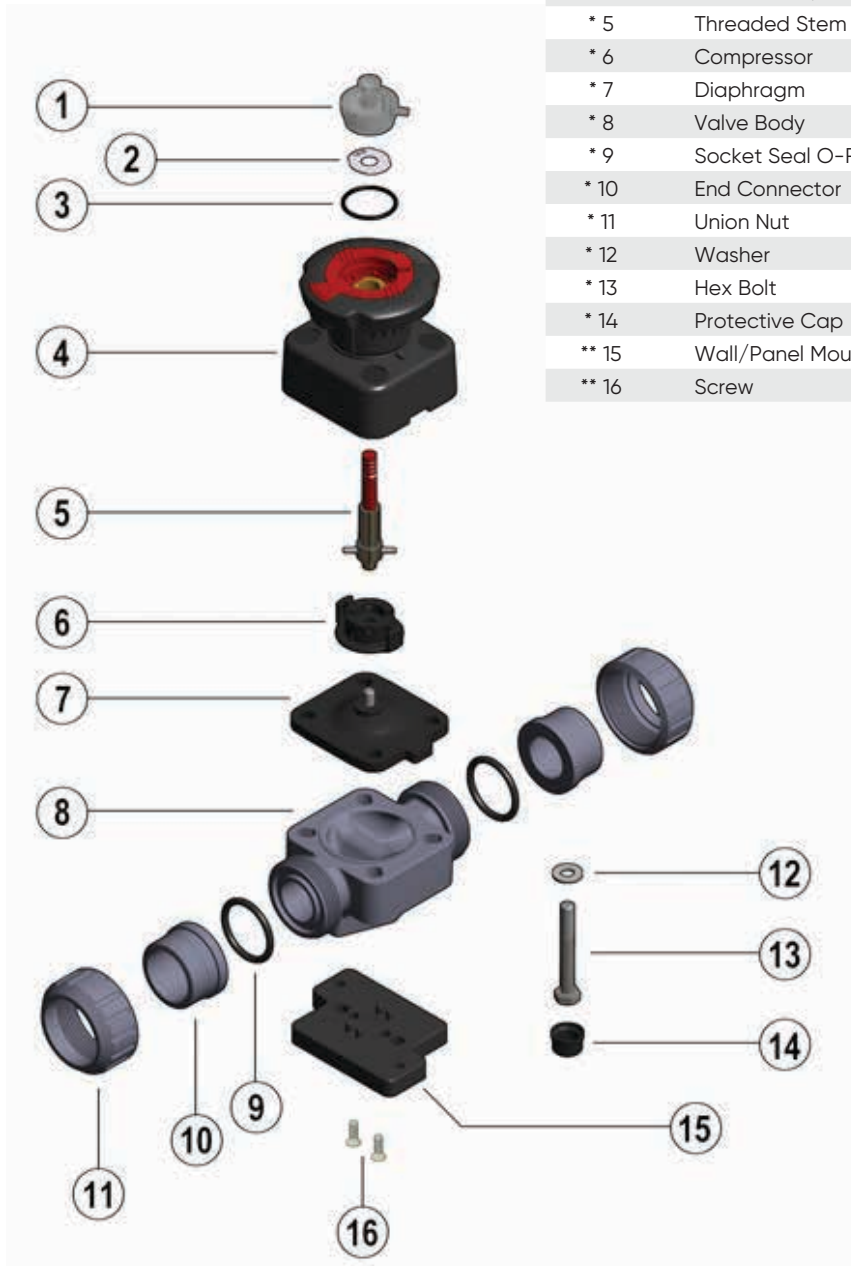

#	Component	Material	Qty
* 1	Transparent Cap	PVC	1
* 2	Labelling Plate	PVC	1
* 3	O-Ring	EPDM	1
* 4	Handwheel / Bonnet	GFPP / PVDF	1
* 5	Threaded Stem - Indicator	SS	1
* 6	Compressor	IXEF®	1
* 7	Diaphragm	EPDM / FPM / PTFE	1
* 8	Valve Body	PVC / CPVC / PP / PVDF	1
* 9	Socket Seal O-Ring	EPDM / FPM	2
* 10	End Connector	PVC / CPVC / PP / PVDF	2
* 11	Union Nut	PVC / CPVC / PP / PVDF	2
* 12	Washer	SS	4
* 13	Hex Bolt	SS	4
* 14	Protective Cap	PE	4
** 15	Wall/Panel Mounting Plate	GFPP	1
** 16	Screw	SS	2

* Spare parts available.

Items 1 through 6 are supplied as an assembly.

** Accessories

Contact IPEX for availability of spare components for Spigot and Flanged style valves.

DK Series Manual Diaphragm Valves

Submittal Data Sheet

Installation Procedures

1. The valve may be installed in any position or direction.
2. Please refer to the appropriate connection style subsection:
 - a. For spigot style, solvent cement each pipe onto the ends of the valve body. Ensure that excess solvent does not run into the body of the valve.
 - b. For true union style, remove the union nuts and slide them onto the pipe.
 - i. For socket style, solvent cement the end connectors onto the pipe ends. For correct joining procedure, please refer to the section entitled, "Joining Methods – Solvent Cementing" in the IPEX Industrial Technical Manual Series, "Volume I: Vinyl Process Piping Systems". Ensure that excess solvent does not run into the body of the valve. Be sure to allow sufficient cure time before continuing with the valve installation.
 - ii. For threaded style, thread the end connectors onto the pipe ends. For correct joining procedure, please refer to the section entitled, "Joining Methods – Threading" in the IPEX Industrial Technical Manual Series, "Volume I: Vinyl Process Piping Systems".
 - iii. Ensure that the socket o-rings are properly fitted in their grooves then carefully place the valve in the system between the two end connections.
 - iv. Tighten both union nuts. Hand tightening is typically sufficient to maintain a seal for the maximum working pressure. Over-tightening may damage the threads on the valve body and/or the union nut, and may even cause the union nut to crack.
 - c. For flanged style, join both flanges to the pipe flanges. For correct joining procedure, please refer to the section entitled, "Joining Methods – Flanging" in the IPEX Industrial Technical Manual Series, "Volume I: Vinyl Process Piping Systems".
3. If anchoring is required, fix the valve to the supporting structure using the wall/panel mounting kit.

Locking Device

The DK valve is equipped with the Dialock® handwheel locking system that prevents the valve from being opened or closed.

The Dialock system can be engaged by simply lifting the handwheel (4) once the required valve position has been reached.

To release the operating mechanism, simply return the handwheel (4) to its previous position by pushing it downwards.



DK Series Manual Diaphragm Valves

Submittal Data Sheet

Installation Procedures, continued

Stroke Limiter (optional)

The DKL version of the diaphragm valve is equipped with a handwheel stroke control system which allows the minimum and maximum flows to be preset and the diaphragm to be protected from excessive compression during closing.

The stroke limiter allows the valve stroke to be modified using the two independent adjusting screws, which determine the mechanical limits of the valve during opening and closing.

The valve is sold with the stroke limiters positioned such that they do not limit the opening or closing stroke.

To access and set the adjusting screws, remove the transparent cap on top of the bonnet.

Travel stop adjustment. Minimum flow rate or closed valve.

1. Rotate the handwheel clockwise until the required minimum flow rate is reached or the valve is closed.
2. Screw in nut (D) as far as it will go and lock it in this position by tightening the locknut (E).

To deactivate the function of limiting the closing stroke, completely unscrew nuts (D and E). This way, the valve will fully close.

3. Re-assemble the transparent cap making sure that the seal o-ring remains properly seated.

Stroke limiter adjustment. Maximum flow rate

1. Rotate the handwheel counter-clockwise until the required maximum flow rate is reached.
2. Rotate knob (F) counter-clockwise as far as the stop. The labelling plate indicates the direction of rotation of the handwheel required to obtain a higher or lower maximum flow rate.

If the opening stroke does not need to be limited, rotate the knob (F) clockwise a number of times. This way, the valve will fully open.

3. Re-assemble the transparent cap making sure that the seal O-Ring remains properly seated.



DK Series Manual Diaphragm Valves

Submittal Data Sheet

Disassembly

1. If removing the valve from an operating system, isolate the valve from the rest of the line. **Be sure to depressurize and drain the valve and isolated branch.**
2. If necessary, detach the valve from the support structure by disassembling the wall/panel mounting kit attached to the bottom of the valve body (8).
3. Please refer to the appropriate connection style subsection:
 - a. For spigot style, cut the pipe on either side of the valve and remove from the line.
 - b. For true union style, loosen both union nuts and drop the valve out of the line. If retaining the socket o-rings (9), take care that they are not lost when removing the valve from the line.
 - c. For flanged style, loosen each bolt holding the valve to the pipe flanges. Please refer to the section entitled, "Joining Methods – Flanging" in the IPEX Industrial Technical Manual Series, "Volume I: Vinyl Process Piping Systems" for a recommended bolt tightening pattern diagram. Follow the same pattern when disassembling the flanged joints then carefully remove the valve from the line.
4. Remove the protective caps (14), then loosen and remove the bolts (13) and washers (12) from the bottom of the valve body.
5. Separate the valve body (8) from the handwheel/bonnet (4).
6. Rotate the handwheel/bonnet (4) clockwise to free the threaded stem (5), compressor (6) and diaphragm (7).
7. Unscrew the diaphragm (7) and remove the compressor (6).
8. The valve components can now be checked for problems and/or replaced.

Note: It is not recommended to attempt to further disassemble the handwheel/bonnet assembly as it may cause irreversible damage to the components.

Assembly

Note: Before assembling the valve components, it is advisable to lubricate the o-rings with a water soluble lubricant.

Be sure to consult the "IPEX Chemical Resistance Guide" and/or other trusted resources to determine specific lubricant-rubber compatibilities.

1. Insert the compressor (6) on the threaded stem (5) aligning it correctly with the reference pin on the stem.



2. Screw the diaphragm (7) on the threaded stem (5).
3. Lubricate the threaded stem (5), insert it in the bonnet (4), and rotate the handwheel/bonnet counter-clockwise until the stem is fully engaged (5). Make sure that the compressor (6) and diaphragm are correctly aligned with the housing in the bonnet.
4. Fit the handwheel/bonnet (4) on the valve body (8) and tighten the bolts (13) and washers (12).
5. Tighten the bolts (13) in an even (cross-like) pattern, ensuring that recommended tightening torque found on the instruction sheet is followed.
6. Replace the protection caps on the bolt heads (14).

Note: During assembly, it is advisable to lubricate the threaded stem. Mineral oils are not recommended for this task as they react aggressively with EPDM rubber.

DK Series Manual Diaphragm Valves

Submittal Data Sheet

Testing and Operation

The purpose of system testing is to assess the quality of all joints and fittings to ensure that they will withstand the design working pressure, plus a safety margin, without loss of pressure or fluid. Typically, the system will be tested and assessed in sub-sections as this allows for improved isolation and remediation of potential problems. With this in mind, the testing of a specific installed valve is achieved while carrying out a test of the overall system.

An onsite pressure test procedure is outlined in the IPEX Industrial Technical Manual Series, "Volume I: Vinyl Process Piping Systems" under the section entitled, "Testing". The use of this procedure should be sufficient to assess the quality of a valve installation. **In any test or operating condition, it is important to never exceed the pressure rating of the lowest rated appurtenance in the system.**

Important points:

- **Never test thermoplastic piping systems with compressed air or other gases including air-over-water boosters.**
- When testing, do not exceed the rated maximum operating pressure of the valve.
- Avoid the rapid closure of valves to eliminate the possibility of water hammer which may cause damage to the pipeline or the valve.

Please contact IPEX customer service and technical support with regard to any concern not addressed in this data sheet or the technical manual.

About the IPEX Group of Companies

As leading suppliers of thermoplastic piping systems, the IPEX Group of Companies provides our customers with some of the world's largest and most comprehensive product lines. All IPEX products are backed by more than 50 years of experience. With state-of-the-art manufacturing facilities and distribution centers across North America, we have established a reputation for product innovation, quality, end-user focus and performance.

Markets served by IPEX group products are:

- Electrical systems
- Telecommunications and utility piping systems
- Industrial process piping systems
- Municipal pressure and gravity piping systems
- Plumbing and mechanical piping systems
- Electrofusion systems for gas and water
- Industrial, plumbing and electrical cements
- Irrigation systems
- PVC, CPVC, PP, PVDF, PE, ABS, and PEX pipe and fittings

This literature is published in good faith and is believed to be reliable. However, it does not represent and/or warrant in any manner the information and suggestions contained in this brochure. Data presented is the result of laboratory tests and field experience.

A policy of ongoing product improvement is maintained. This may result in modifications of features and/or specifications without notice.