

# NONMETALLIC LIGHT FIXTURES



*Sceptalight*<sup>™</sup>

Technical Information



ELECTRICAL SYSTEMS

- LED Light Fixtures
- Incandescent Light Fixtures
- Compact Fluorescent Light Fixtures



**IPEX**  
by aliaxis

[www.ipexna.com](http://www.ipexna.com)

# Sceptalight™ Nonmetallic Light Fixtures

- CSA certified to U.S. standards for wet location use C22.2 No. 250/UL 1598
- CSA certified to U.S. standards for use in hazardous locations.  
(Approved for hazardous locations only when factory-assembled with heat-treated globe and not applicable to LEDs.)  
UL 844
- UL approved for marine locations (salt water) UL 1598A (Not applicable to LEDs)
- LEDs approved for NEMA 4X and IP66 CSA C22.2 250/UL 1598
- LED Light Engine: UL 1598C

Use Sceptalight fixtures in all types of indoor or outdoor agricultural, marine and industrial applications. Typical applications include:

The fixtures are ideal for illuminating walkways, bridges, tunnels, refrigeration coolers and task areas where corrosion of metallic fixtures are a concern – like the food processing industry and car washes. They are also well suited for security, warning, deterrent, directional or general-purpose area lighting. 'Hazardous Location' ratings permit use in many industrial applications as well.

- |                            |                                   |                      |
|----------------------------|-----------------------------------|----------------------|
| • Agricultural facilities  | • Water & Sewage treatment plants | • Off-shore & marine |
| • Manufacturing facilities | • Chemical plants                 | • Mining facilities  |
| • Petrochemical processing |                                   |                      |

## Product Dimensions

Ceiling Mount

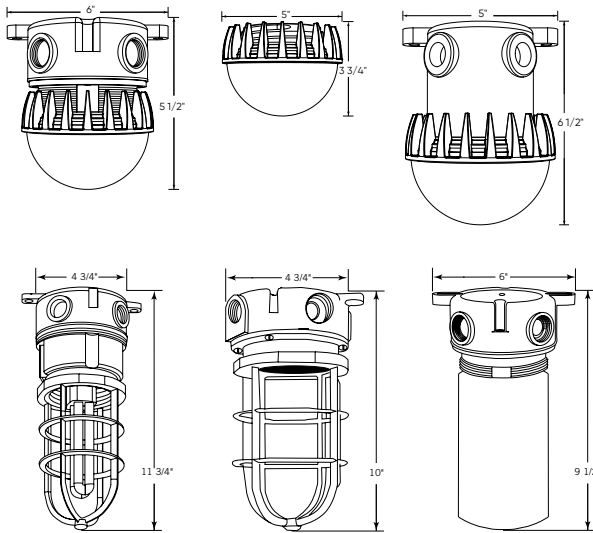

Pendant Mount

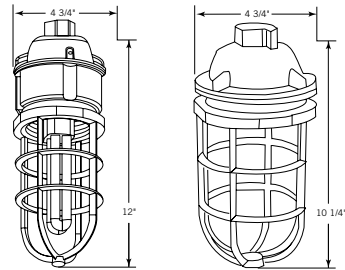

Wall Mount

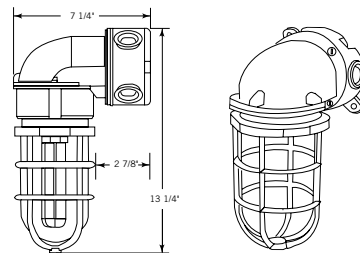

Ceiling Mount Utility Fixtures

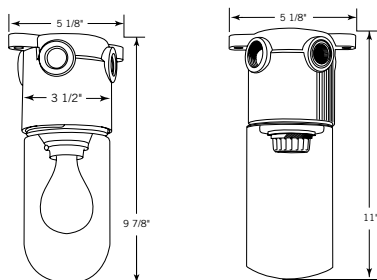

## Applications

### Wet Location Use

Wet Locations are defined as locations in which liquids may drip, splash or flow on or against electrical equipment. This can include places subject to saturation with water and other liquids such as vehicle washing areas and unprotected locations exposed to weather.

### Hazardous Location Use

Sceptalight fixtures are listed and approved for 'Hazardous Location' use in:

- Class I, Div. 2 Groups A, B, C, & D
- Class II, Div. 2 Groups F & G

The following information is provided as an overview of Hazardous Location environments only. Refer to the NEC for the complete requirements of Hazardous Locations.

The determination of a Hazardous Location (Class and Division) is the responsibility of the project engineer just as it is the installer's responsibility to be both knowledgeable and certified to perform work in hazardous locations. Always consult with the local electrical inspection authority regarding appropriate use and installation of products.

Hazardous Locations are areas classified according to the nature of the hazard and divided into divisions that further define the potential hazard based on conditions that exist.

### Marine Location Use

The marine location certification, UL 1598A, is a supplemental approval to the wet location standard that allows the luminaires to be used in salt water environments. The standard specifically evaluates for conditions such as salt spray corrosion, ignition protection, UV exposure and water ingress. (Not applicable to LEDs)

**Class I:** In Class I locations, flammable gases or vapors are or may be present in the air in sufficient quantities that they may ignite or become explosive.

**Class II:** In Class II locations, it is the presence of combustible or electrically conductive dusts that pose the hazard.

**Division 2:** In Division 2 locations, the potential hazard is confined in containers or in a closed system and/or the area has positive ventilation that normally prevents the gases, vapors or dusts from reaching ignitable concentrations.

Explosive characteristics of gases, vapors or dusts vary with the specific material; it is therefore necessary that equipment installed within the hazardous location is identified for the specific group of gas, vapor or dust for which it is approved.

GROUP A	GROUP B	GROUP C	GROUP D	GROUP F	GROUP G
Acetylene	Hydrogen	Ethylene	Propane	Carbon Black Dust	Flour Dust
	Ethylene Oxide	Hydrogen Sulfide	Natural Gas	Coal Dust	Starch Dust
	Butadiene	Diethyl Ether	Alcohol	Coke Dust	Grain Dust
	Propylene Oxide	Acetaldehyde	Ammonia		and Other Dusts of Similar Characteristics
		Cyclopropane	Benzine		
			Butane		
			Acetone		
			Gasoline		
			Lacquer Solvent Vapors		

Tested according to IES procedures. Test distance exceeds five times the greatest luminous opening of luminaire. Dec. 8, 2004

<sup>1</sup> Dowcorning.com – rubber physical and chemical properties

<sup>2</sup> Dupont.com – product information Rynite® PET

## Product Characteristics

### Temperature Codes

The temperature marking, specified by the T code on the fixture label, indicates the maximum surface temperature of the specific electrical equipment. In Class I Hazardous Locations, equipment shall not be installed in an area where vapors or gases are present that have an ignition temperature less than the maximum external temperature rating of the equipment.

- Incandescent – Temperature Code T2B 500°F (260°C)
- Fluorescent – Temperature Code T3A 356°F (180°C)

### Threaded Hub Connection

Many of the diverse threaded conduit fitting products are tapered to ensure tight connections are made. To avoid potential for stress cracking as a result of over-tightening, install the terminal adapter fitting into the hub 1/2 turn past hand-tight. Teflon® tape or Teflon® pipe dope may be used to ensure a watertight connection.

### Compact Fluorescent Lamps

The compact fluorescent lamps provided with the Sceptalight fixture have either 2 pins or 4 pins. Each 2-pin lamp has an internal starter and is designed for preheat, magnetic operation. The 4-pin lamps are designed for electronic ballast operation and do not have an internal starter; starting the lamps is a function of the ballast provided with each fixture.

### Ballasts

NOMINAL WATTAGE (W)	AVG. RATED LIFE (HRS)	BASE	NO. PINS
7	10000	G23	2
9	10000	G23	2
13	10000	GX23	2
18	12000	G24Q-2	4
26	12000	G24Q-3	4

Sceptalight 18W and 26W fluorescents include high power factor electronic ballasts with inherent thermal protection for a minimum start temperature -13°F (-25°). Also, these ballasts have an end-of-life (de-active lamp) protection circuit to prevent damage to the light fixture components from potential high current flow. At start-up, fluorescent fixtures require a high current, which stabilizes once the lamp is lit. However, if the lamp is broken or burnt out, the high starting current could cause damage to the electrical components of the fixture.

Sceptalight 7W, 9W and 13W fluorescents include normal power factor (typically 40-60%) magnetic ballasts with a minimum start temperature of 50°F (10°C).

All of the ballasts offered include an Auto Restart after Hot feature, which allows the lamp to be pulled out and replaced while the power is still on and the lamp will

re-strike automatically. The Total Harmonic Distortion (THD) for all ballasts is less than 15%.

### Dielectric Strength

Dielectric strength is the measurement (in volts per mil) of

NOMINAL WATTAGE (W)	BALLAST TYPE	INPUT CURRENT (AMPS)	POWER FACTOR
7	Magnetic	0.21A	NPF
9	Magnetic	0.21A	NPF
13	Magnetic	0.26A	NPF
18	Electronic	0.15A	≥ 0.99
26	Electronic	0.21A	≥ 0.99

the maximum electric field strength an insulating material can withstand intrinsically without breaking down (i.e. without experiencing failure of its insulating properties).

Rubber, one of the better insulating materials available, offers a good example for comparing dielectric strength. Evaluating values on a 1/8" thick sample, the dielectric strength of general purpose rubber is ~400 V/mil' while the dielectric strength of PET material (Rynite) is 355 V/mil<sup>2</sup>.

### Installation

The ceiling and wall mount boxes each have four 3/4" threaded hubs with liquid-tight knockouts. Two feet are spaced at 5-1/4" for base up installation. Pendant mount fixtures have a single 3/4" threaded hub. The minimum supply wires must be rated as shown below:

It should be noted that the Wet location light fixtures

LOCATION	MIN. SUPPLY WIRE RATING
Wet	60 °C
Wet (Utility Fixture)	75 °C
Marine	110 °C
Hazardous	90 °C

require minimum 60°C supply wires; however, the label on the fixture states that minimum 90°C supply wires must be used. If requested by a customer, a letter of certification supporting this fact can be provided.

LUMEN OUTPUT	1575 LM
INPUT VOLTAGE	120 VAC
FREQUENCY	60 HZ
NOMINAL POWER	15 W
COLOR TEMPERATURE 5000 K	5000 K
POWER FACTOR	> 0.98
TOTAL HARMONIC DISTORTION	10.50%
OPERATING TEMPERATURE	-40°C to 40°C
DIMMABILITY RANGE	down to 5%
CRI	> 80

---

## LEDs

### RoHS

The Sceptalight product offering is compliant with the new RoHS Directive. RoHS, established by the European Union (EU), restricts the use of six hazardous materials listed below that can be manufactured within electronic/electrical equipment. The maximum concentrations are 0.1% (except for Cadmium which is limited to 0.01%) by weight of homogeneous material.

RoHS restricts the use of several substances:

1. Lead,
2. Mercury,
3. Cadmium,
4. Cadmium VI  
(also known as hexavalent chromium or Cr6+),
5. Polybrominated Biphenyls (PBB), and
6. Polybrominated Diphenyl Ester/Ether (PBDE).

### Bonding

As stated in the NEC, metal raceways are required to meet the ground-fault current performance requirements of 250.4 (A) & (B), which states that "non-current carrying conductive materials enclosing electrical conductors or equipment, or forming part of such equipment, shall be connected together and to the electrical supply source in a manner that establishes an effective ground-fault current path".

Several methods for effective bonding are provided within section 250 of the NEC for various types of applications, such as; Bonding at the Service (250.92 (A) & (B)), Bonding Other Enclosures (250.96), Bonding in Hazardous (Classified) Locations (250.100), etc. Each of these applications requires different bonding methods to establish the necessary ground-fault current path.

The NEC indicates that for all applications and locations that the Sceptalight nonmetallic light fixtures will be used, bonding-type locknuts and bushings can be used to bond a metal raceway.

The Underwriters Laboratories General Information Directory (commonly referred to as the UL White Book) describes bonding bushings and grounding bushings as follows:

**Bonding Bushing:** A bonding bushing provides a means to make a reliable connection between a metal conduit and an enclosure. This means is typically one or more set screws.

**Grounding Bushing:** Provide a means to make a bonding connection between a conduit and enclosure, and also have some mechanism for connecting a bonding wire.

# Certified IESNA LM-79 Test Report for LLED-15/LVPE-LED/LVPF-LED

Sceptalight LED products include the LLED-15 Retrofit Light Engine and LVPE-LED and LVPF-LED light fixture models. One LLED-15 Light Engine 15W 120v frosted globe. For photometric files, visit ipexna.com.

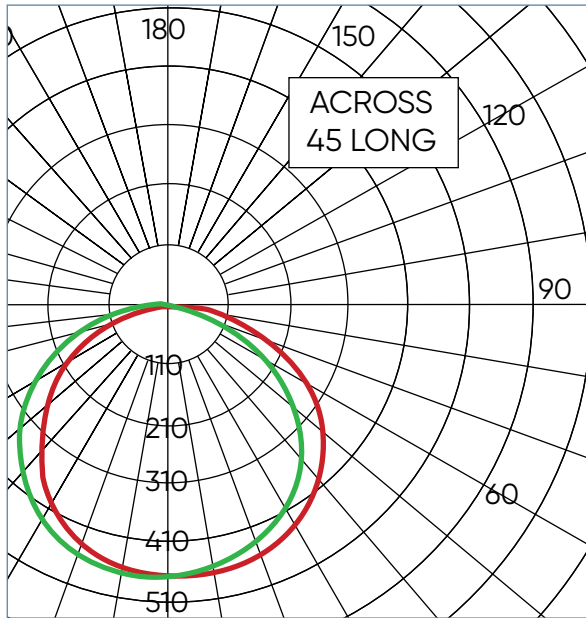

CANDLEPOWER SUMMARY

		HORIZONTAL					
		ANGLE	0	22.5	45	67.5	90
VERTICAL	0	542.7	542.7	542.7	542.7	542.7	
	5	539.5	538.5	537.9	537.8	538.0	
	10	533.6	531.9	530.7	529.9	530.9	
	15	524.5	522.0	520.1	519.5	520.4	
	20	511.7	507.7	505.0	504.0	505.7	
	25	494.1	489.2	485.0	484.3	486.8	
	30	471.9	465.6	460.7	459.7	462.8	
	35	445.1	437.0	431.2	430.0	434.4	
	40	412.6	402.5	395.5	394.1	399.5	
	45	372.6	360.0	351.7	350.4	355.7	
	50	323.7	310.4	301.9	300.1	305.4	
	55	272.8	259.2	250.4	248.5	254.6	
	60	222.2	207.3	198.4	196.2	202.0	
	65	170.7	157.5	149.4	147.4	152.0	
	70	124.6	114.5	108.0	106.6	110.4	
	75	87.7	81.1	76.9	76.0	77.9	
	80	62.1	58.7	56.6	56.1	56.9	
	85	46.1	44.3	43.4	43.3	43.8	
90	35.4	34.2	34.0	34.1	34.8		

AVERAGE LUMINANCE DATA

ANGLE	LUMINANCE
0	17955
45	11624
55	10405
65	8802
75	6423
85	5585

ZONAL, LUMENS AND PERCENTAGES

ZONE	LUMENS	% LUMINAIRE
0 - 40	670	39.30
0 - 60	1222	71.70
0 - 80	1573	92.40
0 - 90	1657	97.30
0 - 180	1703	100.00

COEFFICIENTS OF UTILIZATION ZONAL CAVITY METHOD  
EFFECTIVE FLOOR CAVITY REFLECTANCE = .20

CC	80			70			50			30			10			0
WALL	50	30	10	50	30	10	50	30	10	50	30	10	50	30	10	0
RCR																
0	1.18	1.18	1.18	1.15	1.15	1.15	1.10	1.10	1.10	1.04	1.04	1.04	.00	.00	.00	.97
1	1.01	.96	.92	.99	.94	.90	.94	.90	.87	.89	.86	.84	.85	.83	.81	.78
2	.87	.80	.74	.85	.78	.73	.81	.75	.70	.77	.73	.68	.74	.70	.66	.64
3	.76	.68	.61	.74	.66	.60	.71	.64	.58	.68	.62	.57	.65	.60	.56	.53
4	.67	.58	.51	.66	.57	.50	.63	.55	.49	.60	.54	.48	.58	.52	.47	.45
5	.60	.50	.44	.59	.50	.43	.56	.48	.42	.54	.47	.42	.52	.46	.41	.39
6	.54	.44	.38	.53	.44	.38	.51	.43	.37	.49	.42	.36	.47	.41	.36	.34
7	.49	.40	.33	.48	.39	.33	.46	.38	.33	.44	.37	.32	.43	.36	.32	.30
8	.44	.36	.29	.43	.35	.29	.42	.34	.29	.40	.34	.29	.39	.33	.28	.26
9	.41	.32	.26	.40	.32	.26	.38	.31	.26	.37	.30	.26	.36	.30	.25	.24
10	.37	.29	.24	.37	.29	.24	.36	.28	.24	.34	.28	.23	.33	.27	.23	.21

Tested according to IES procedures. Test distance exceeds five times the greatest luminous opening of luminaire.  
Determined in accordance with current IES published procedures Luminaire input watts = 15  
Laboratory result may not be representative of field performance.

IPEX Non-metallic ceiling mount light fixture Cat. No. LVPF150 with clear glass jar lens and plastic protective guard.  
 One 150w 120v coated A21 soft white incandescent lamp.  
 Lumen Rating = 2780 LMS. For photometric files, visit ipexna.com.

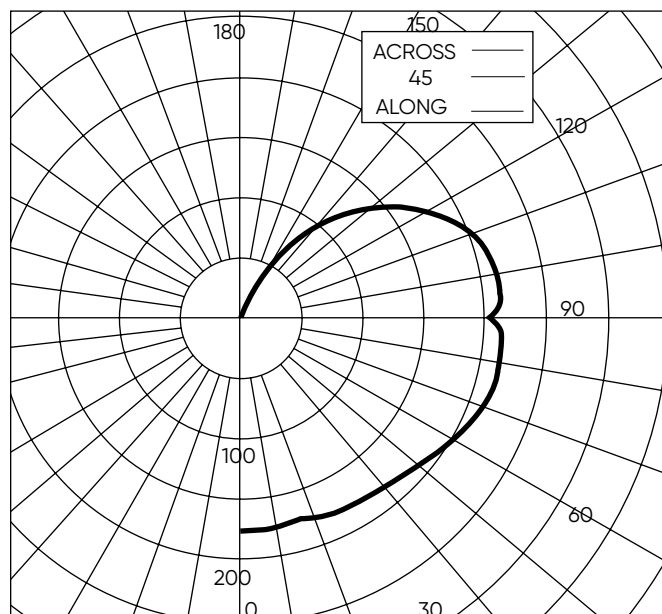

CANDLEPOWER SUMMARY

ANGLE	MEAN CP	LMS	ANGLE	MEAN CP	LMS
0	176		90	205	
5	175	17	95	214	232
10	175		100	213	
15	174	50	105	210	221
20	177		110	203	
25	179	83	115	191	189
30	181		120	175	
35	181	114	125	159	142
40	184		130	142	
45	187	145	135	123	95
50	191		140	99	
55	197	177	145	73	47
60	203		150	48	
65	208	206	155	28	14
70	213		160	13	
75	216	227	165	3	1
80	216		170	0	
85	215	233	175	0	0
90	205		180	0	

AVERAGE LUMINANCE DATA

ANGLE	LUMINANCE	
0	28413	(8292)
30	16907	(4934)
40	15457	(4511)
45	15147	(4421)
50	15075	(4399)
55	15169	(4427)
60	15448	(4508)
65	15764	(4601)
70	16143	(4711)
75	16541	(4827)
80	16860	(4920)
85	17187	(5016)

ZONAL, LUMENS AND PERCENTAGES

ZONE	LUMENS	% LAMP	% LUMINAIRE
0 - 30	149	5.37	6.82
0 - 40	263	9.47	12.01
0 - 60	584	21.03	26.67
0 - 90	1250	45.00	57.06
40 - 90	987	35.52	45.05
60 - 90	666	23.96	30.39
90 - 180	941	33.86	42.94
0 - 180	2192	78.85	100.00

Efficiency = 78.9% S/MH = 1.6 SC = 1.6

COEFFICIENTS OF UTILIZATION ZONAL CAVITY METHOD  
 EFFECTIVE FLOOR CAVITY REFLECTANCE = .20

CC	80				70				50			30			10			0
	70	50	30	10	70	50	30	10	50	30	10	50	30	10	50	30	10	0
WALL																		
RCR																		
0	.86	.86	.86	.86	.80	.80	.80	.80	.69	.69	.69	.59	.59	.59	.49	.49	.49	.45
1	.75	.70	.65	.61	.69	.64	.60	.56	.55	.52	.49	.46	.44	.41	.38	.36	.34	.30
2	.66	.59	.52	.47	.61	.54	.48	.43	.46	.41	.37	.38	.35	.32	.31	.28	.26	.22
3	.60	.50	.43	.37	.55	.46	.40	.35	.39	.34	.30	.32	.29	.25	.26	.23	.20	.17
4	.54	.44	.37	.31	.50	.41	.34	.29	.34	.29	.25	.29	.24	.21	.23	.20	.17	.14
5	.49	.38	.31	.26	.45	.36	.29	.24	.30	.25	.21	.25	.21	.17	.20	.17	.14	.11
6	.45	.34	.27	.22	.41	.32	.25	.20	.27	.21	.17	.22	.18	.15	.18	.14	.12	.09
7	.41	.30	.23	.18	.38	.28	.22	.17	.24	.18	.15	.20	.15	.12	.16	.13	.10	.08
8	.38	.27	.21	.16	.35	.25	.19	.15	.21	.16	.13	.18	.14	.11	.15	.11	.09	.07
9	.35	.25	.18	.14	.33	.23	.17	.13	.19	.15	.11	.16	.12	.09	.13	.10	.07	.06
10	.33	.23	.16	.12	.30	.21	.15	.11	.18	.13	.10	.15	.11	.08	.12	.09	.06	.05

Tested according to IES procedures. Test distance exceeds five times the greatest luminous opening of luminaire.  
 Determined in accordance with current IES published procedures Luminaire input watts = 146.2  
 Laboratory result may not be representative of field performance. Ballast factors have not been applied.

IPEX Non-metallic ceiling mount light fixture Cat. No. LVPF150C with clear glass jar lens and plastic protective guard.  
 One 100w 120v coated A19 soft white incandescent lamp.  
 Lumen Rating = 1470 LMS. For photometric files, visit ipexna.com.

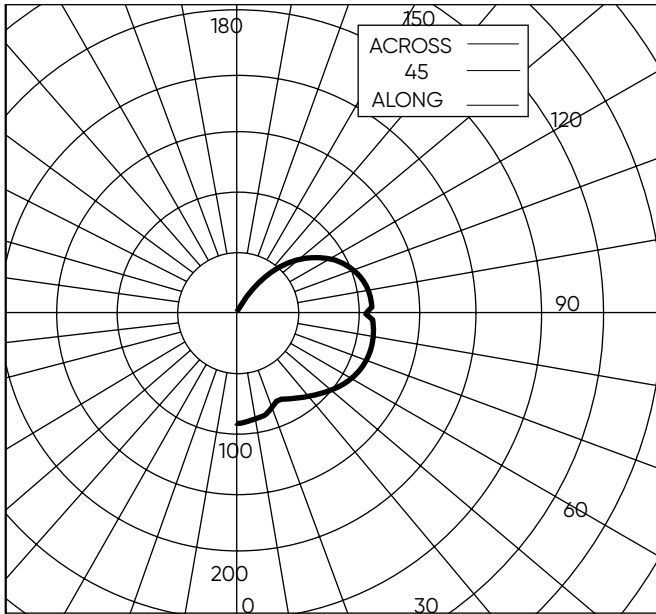

CANDLEPOWER SUMMARY

ANGLE	MEAN CP	LMS	ANGLE	MEAN CP	LMS
0	91		90	107	
5	91	9	95	112	121
10	89		100	111	
15	88	25	105	108	114
20	85		110	104	
25	81	38	115	99	98
30	82		120	91	
35	86	54	125	82	73
40	91		130	71	
45	96	74	135	59	46
50	101		140	45	
55	105	94	145	31	20
60	109		150	17	
65	112	111	155	7	4
70	114		160	1	0
75	116	122	165	0	0
80	116		170	0	
85	114	123	175	0	0
90	107		180	0	

AVERAGE LUMINANCE DATA

ANGLE	LUMINANCE	
0	14732	(4299)
30	7668	(2238)
40	7631	(2227)
45	7754	(2263)
50	7917	(2310)
55	8109	(2366)
60	8297	(2421)
65	8463	(2470)
70	8654	(2525)
75	8895	(2596)
80	9020	(2632)
85	9107	(2658)

ZONAL, LUMENS AND PERCENTAGES

ZONE	LUMENS	% LAMP	% LUMINAIRE
0 - 30	71	4.84	6.32
0 - 40	125	8.52	11.12
0 - 60	293	19.96	26.07
0 - 90	649	44.18	57.71
40 - 90	524	35.67	46.58
60 - 90	356	24.22	31.63
90 - 180	475	32.38	42.29
0 - 180	1125	76.56	100.00

Efficiency = 76.6% S/MH = 1.5 SC = 1.5

COEFFICIENTS OF UTILIZATION ZONAL CAVITY METHOD  
 EFFECTIVE FLOOR CAVITY REFLECTANCE = .20

CC	80				70				50			30			10			0
	70	50	30	10	70	50	30	10	50	30	10	50	30	10	50	30	10	0
WALL																		
RCR																		
0	.83	.83	.83	.83	.78	.78	.78	.78	.67	.67	.67	.57	.57	.57	.48	.48	.48	.44
1	.72	.67	.63	.59	.67	.62	.59	.55	.53	.50	.47	.45	.42	.40	.37	.35	.33	.29
2	.64	.57	.50	.45	.59	.52	.47	.42	.44	.40	.36	.37	.33	.30	.30	.27	.25	.21
3	.58	.48	.41	.36	.53	.45	.38	.33	.38	.33	.28	.31	.27	.24	.25	.22	.20	.16
4	.52	.42	.35	.29	.48	.39	.33	.27	.33	.28	.24	.27	.23	.20	.22	.19	.16	.13
5	.48	.37	.30	.24	.44	.34	.28	.23	.29	.24	.19	.24	.20	.16	.19	.16	.13	.11
6	.44	.33	.26	.20	.40	.30	.24	.19	.26	.20	.16	.21	.17	.14	.17	.14	.11	.09
7	.40	.29	.22	.17	.37	.27	.21	.16	.23	.17	.14	.19	.15	.11	.15	.12	.09	.07
8	.37	.26	.20	.15	.34	.24	.18	.14	.21	.16	.12	.17	.13	.10	.14	.11	.08	.06
9	.34	.24	.17	.13	.31	.22	.16	.12	.19	.14	.10	.16	.12	.09	.13	.09	.07	.05
10	.32	.22	.15	.11	.29	.20	.14	.11	.17	.12	.09	.14	.10	.07	.12	.08	.06	.04

Tested according to IES procedures. Test distance exceeds five times the greatest luminous opening of luminaire.  
 Determined in accordance with current IES published procedures Luminaire input watts = 96.2  
 Laboratory result may not be representative of field performance. Ballast factors have not been applied.



IPEX Non-metallic ceiling mount light fixture Cat. No. LVPL13C with clear glass jar lens and plastic protective guard.  
 One 13w twin-tube compact fluorescent lamp. One Etlin-Daniels 120v 1-lamp magnetic ballast no. CF-1322T-CC-TP.  
 Lumen Rating = 800 LMS. For photometric files, visit ipexna.com.

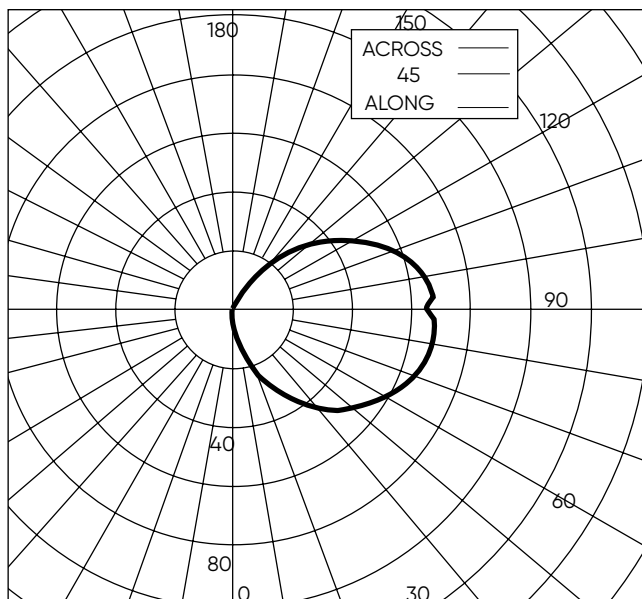

CANDLEPOWER SUMMARY

ANGLE	MEAN CP	LMS	ANGLE	MEAN CP	LMS
0	5		90	66	
5	7	1	95	67	73
10	12		100	65	
15	17	5	105	62	65
20	22		110	57	
25	27	13	115	52	51
30	32		120	45	
35	38	24	125	39	35
40	44		130	33	
45	49	38	135	27	21
50	53		140	20	
55	56	51	145	14	9
60	60		150	8	
65	63	63	155	4	2
70	66		160	1	
75	68	72	165	0	0
80	69		170	0	
85	69	74	175	0	0
90	66		180	0	

AVERAGE LUMINANCE DATA

ANGLE	LUMINANCE
0	726 (212)
30	3031 (884)
40	3694 (1078)
45	3973 (1159)
50	4146 (1210)
55	4351 (1270)
60	4562 (1331)
65	4802 (1401)
70	5014 (1463)
75	5212 (1521)
80	5368 (1566)
85	5511 (1608)

ZONAL, LUMENS AND PERCENTAGES

ZONE	LUMENS	% LAMP	% LUMINAIRE
0 - 30	18	2.32	3.12
0 - 40	42	5.33	7.16
0 - 60	131	16.38	21.99
0 - 90	339	42.47	57.03
40 - 90	297	37.14	49.87
60 - 90	208	26.10	35.04
90 - 180	255	32.00	42.97
0 - 180	595	74.47	100.00

Efficiency = 74.5% S/MH = 5.9 SC = 5.4

COEFFICIENTS OF UTILIZATION ZONAL CAVITY METHOD  
 EFFECTIVE FLOOR CAVITY REFLECTANCE = .20

CC WALL RCR	80				70				50			30			10			0
	70	50	30	10	70	50	30	10	50	30	10	50	30	10	50	30	10	0
0	.81	.81	.81	.81	.75	.75	.75	.75	.65	.65	.65	.55	.55	.55	.47	.47	.47	.42
1	.70	.65	.60	.56	.64	.60	.56	.52	.50	.47	.44	.42	.40	.37	.34	.32	.31	.27
2	.61	.54	.47	.42	.56	.49	.44	.39	.41	.37	.33	.34	.31	.27	.27	.25	.22	.19
3	.55	.45	.38	.32	.50	.42	.35	.30	.35	.30	.25	.28	.24	.21	.23	.19	.17	.13
4	.50	.39	.32	.26	.45	.36	.30	.24	.30	.25	.21	.25	.20	.17	.19	.16	.13	.10
5	.45	.34	.27	.21	.41	.32	.25	.20	.26	.21	.17	.21	.17	.14	.17	.13	.10	.08
6	.41	.30	.23	.18	.37	.28	.21	.16	.23	.18	.14	.19	.14	.11	.15	.11	.08	.06
7	.37	.27	.20	.15	.34	.24	.18	.13	.20	.15	.11	.16	.12	.09	.13	.09	.07	.05
8	.34	.24	.17	.12	.31	.22	.16	.11	.18	.13	.09	.15	.11	.07	.12	.08	.06	.04
9	.32	.21	.15	.11	.29	.20	.14	.10	.16	.11	.08	.13	.09	.06	.10	.07	.05	.03
10	.29	.19	.13	.09	.27	.18	.12	.08	.15	.10	.07	.12	.08	.05	.10	.06	.04	.02

Tested according to IES procedures. Test distance exceeds five times the greatest luminous opening of luminaire.  
 Determined in accordance with current IES published procedures Luminaire input watts = 15.1  
 Laboratory result may not be representative of field performance. Ballast factors have not been applied.

IPEX Non-metallic ceiling mount light fixture Cat. No. LVPL18C with clear glass jar lens and plastic protective guard.  
 One 18w quad compact fluorescent lamp. One Hatch 120v 1-lamp electronic ballast no. FR-1800  
 Lumen Rating = 1250 LMS. For photometric files, visit ipexna.com.

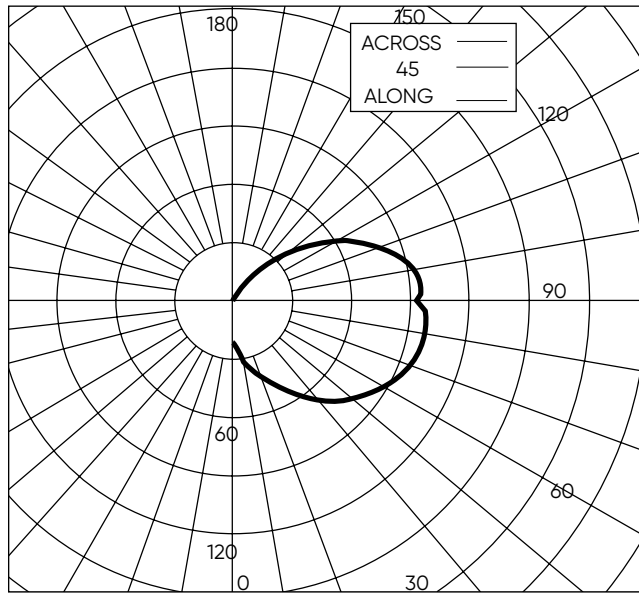

CANDLEPOWER SUMMARY

ANGLE	MEAN CP	LMS	ANGLE	MEAN CP	LMS
0	21		90	94	
5	24	3	95	97	104
10	30		100	94	
15	36	10	105	89	94
20	40		110	82	
25	45	21	115	73	72
30	52		120	63	
35	59	37	125	52	47
40	66		130	42	
45	73	56	135	32	25
50	79		140	23	
55	84	75	145	16	10
60	89		150	9	
65	94	93	155	2	2
70	97		160	0	
75	99	105	165	0	0
80	100		170	0	
85	99	107	175	0	0
90	94		180	0	

AVERAGE LUMINANCE DATA

ANGLE	LUMINANCE
0	3430 (1001)
30	4845 (1414)
40	5586 (1630)
45	5907 (1724)
50	6193 (1807)
55	6470 (1888)
60	6804 (1986)
65	7097 (2071)
70	7346 (2144)
75	7620 (2224)
80	7802 (2277)
85	7945 (2319)

ZONAL, LUMENS AND PERCENTAGES

ZONE	LUMENS	% LAMP	% LUMINAIRE
0 - 30	33	2.71	3.93
0 - 40	71	5.69	8.25
0 - 60	202	16.23	23.52
0 - 90	507	40.59	58.82
40 - 90	436	34.90	50.58
60 - 90	304	24.36	35.31
90 - 180	355	28.41	41.18
0 - 180	862	69.00	100.00

Efficiency = 69.0% S/MH = 3.6 SC = 3.4

COEFFICIENTS OF UTILIZATION ZONAL CAVITY METHOD  
 EFFECTIVE FLOOR CAVITY REFLECTANCE = .20

CC WALL RCR	80				70				50			30			10			0
	70	50	30	10	70	50	30	10	50	30	10	50	30	10	50	30	10	0
0	.75	.75	.75	.75	.70	.70	.70	.70	.61	.61	.61	.52	.52	.52	.44	.44	.44	.41
1	.65	.60	.56	.52	.60	.56	.52	.48	.47	.44	.42	.40	.37	.35	.33	.31	.29	.26
2	.57	.50	.44	.39	.53	.46	.41	.36	.39	.35	.31	.32	.29	.26	.26	.24	.21	.18
3	.51	.42	.36	.30	.47	.39	.33	.28	.33	.28	.24	.27	.23	.20	.22	.19	.16	.13
4	.46	.37	.30	.25	.42	.34	.28	.23	.28	.23	.19	.23	.19	.16	.19	.16	.13	.10
5	.42	.32	.25	.20	.38	.30	.23	.19	.25	.20	.16	.20	.16	.13	.16	.13	.10	.08
6	.38	.28	.21	.17	.35	.26	.20	.15	.22	.17	.13	.18	.14	.11	.14	.11	.08	.06
7	.35	.25	.18	.14	.32	.23	.17	.13	.19	.14	.11	.16	.12	.09	.13	.09	.07	.05
8	.32	.22	.16	.12	.29	.21	.15	.11	.17	.13	.09	.14	.10	.07	.11	.08	.06	.04
9	.30	.20	.14	.10	.27	.19	.13	.09	.16	.11	.08	.13	.09	.06	.10	.07	.05	.03
10	.28	.18	.12	.09	.25	.17	.12	.08	.14	.10	.07	.12	.08	.05	.09	.06	.04	.03

Tested according to IES procedures. Test distance exceeds five times the greatest luminous opening of luminaire.  
 Determined in accordance with current IES published procedures Luminaire input watts = 17.6  
 Laboratory result may not be representative of field performance. Ballast factors have not been applied.

IPEX Non-metallic ceiling mount light fixture Cat. No. LVPL26C with clear glass jar lens and plastic protective guard.  
 One 26w quad compact fluorescent lamp. One Hatch 120v 1-lamp electronic ballast no. FR-2600  
 Lumen Rating = 1825 LMS. For photometric files, visit ipexna.com.

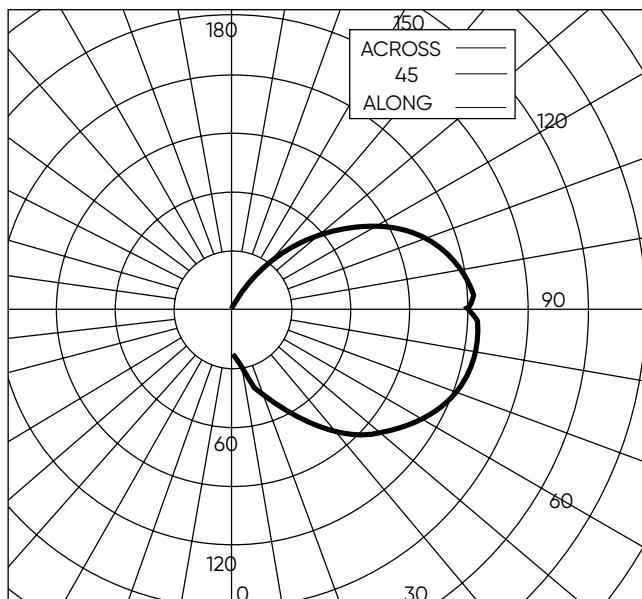

CANDLEPOWER SUMMARY

ANGLE	MEAN CP	LMS	ANGLE	MEAN CP	LMS
0	23		90	120	
5	26	3	95	122	132
10	34		100	118	
15	41	12	105	111	117
20	48		110	103	
25	55	26	115	94	93
30	64		120	83	
35	73	46	125	72	65
40	83		130	60	
45	91	71	135	47	37
50	99		140	35	
55	105	94	145	24	16
60	112		150	15	
65	117	116	155	7	4
70	122		160	2	
75	125	132	165	0	0
80	126		170	0	
85	125	136	175	0	0
90	120		180	0	

AVERAGE LUMINANCE DATA

ANGLE	LUMINANCE	
0	3683	(1075)
30	5980	(1745)
40	6997	(2042)
45	7397	(2158)
50	7764	(2266)
55	8116	(2368)
60	8491	(2478)
65	8871	(2589)
70	9226	(2692)
75	9572	(2793)
80	9841	(2872)
85	10035	(2929)

ZONAL, LUMENS AND PERCENTAGES

ZONE	LUMENS	% LAMP	% LUMINAIRE
0-30	40	2.22	3.70
0-40	86	4.77	7.92
0-60	251	13.80	22.94
0-90	635	34.80	57.83
40-90	548	30.04	49.91
60-90	383	21.00	34.89
90-180	463	25.38	42.17
0-180	1098	60.18	100.00

Efficiency = 60.2% S/MH = 3.8 SC = 3.7

COEFFICIENTS OF UTILIZATION ZONAL CAVITY METHOD  
 EFFECTIVE FLOOR CAVITY REFLECTANCE = .20

CC	80				70				50			30			10			0
	70	50	30	10	70	50	30	10	50	30	10	50	30	10	50	30	10	0
RCR																		
0	.66	.66	.66	.66	.61	.61	.61	.61	.53	.53	.53	.45	.45	.45	.38	.38	.38	.35
1	.56	.52	.49	.45	.52	.48	.45	.42	.41	.38	.36	.34	.32	.30	.28	.27	.25	.22
2	.50	.43	.38	.34	.46	.40	.35	.31	.34	.30	.27	.28	.25	.22	.23	.20	.18	.15
3	.44	.37	.31	.26	.41	.34	.29	.24	.28	.24	.21	.23	.20	.17	.19	.16	.14	.11
4	.40	.32	.26	.21	.37	.30	.24	.20	.25	.20	.17	.20	.17	.14	.16	.13	.11	.09
5	.37	.28	.22	.17	.33	.26	.20	.16	.21	.17	.14	.18	.14	.11	.14	.11	.09	.07
6	.33	.24	.19	.15	.30	.23	.17	.13	.19	.15	.11	.15	.12	.09	.12	.09	.07	.05
7	.30	.22	.16	.12	.28	.20	.15	.11	.17	.12	.09	.14	.10	.07	.11	.08	.06	.04
8	.28	.19	.14	.10	.26	.18	.13	.09	.15	.11	.08	.12	.09	.06	.10	.07	.05	.03
9	.26	.18	.12	.09	.24	.16	.11	.08	.13	.10	.07	.11	.08	.05	.09	.06	.04	.03
10	.24	.16	.11	.08	.22	.15	.10	.07	.12	.08	.06	.10	.07	.05	.08	.05	.03	.02

Tested according to IES procedures. Test distance exceeds five times the greatest luminous opening of luminaire.  
 Determined in accordance with current IES published procedures Luminaire input watts = 22.8  
 Laboratory result may not be representative of field performance. Ballast factors have not been applied.

## SALES AND CUSTOMER SERVICE

Customers call IPEX USA LLC.

Toll free: (800) 463-9572

[www.ipexna.com](http://www.ipexna.com)

### About the IPEX group of companies

As leading suppliers of thermoplastic piping systems, the IPEX Group of Companies provides our customers with some of the largest and most comprehensive product lines. All IPEX products are backed by more than 50 years of experience. With state-of-the-art manufacturing facilities and distribution centers across North America, we have earned a reputation for product innovation, quality, end-user focus and performance.

Markets served by IPEX group products are:

- Electrical systems
- Telecommunications and utility piping systems
- Industrial process piping systems
- Municipal pressure and gravity piping systems
- Plumbing and mechanical piping systems
- Electrofusion systems for gas and water
- Industrial, plumbing and electrical cements
- Irrigation systems
- PVC, CPVC, PP, PVDF, PE, ABS, and PEX pipe and fittings

Sceptalight™ is manufactured by IPEX Electrical Inc. and distributed in the United States by IPEX USA LLC.

Sceptalight™ is a registered trademark of IPEX Branding Inc.

This literature is published in good faith and is believed to be reliable. However it does not represent and/or warrant in any manner the information and suggestions contained in this brochure. Data presented is the result of laboratory tests and field experience.

A policy of ongoing product improvement is maintained. This may result in modifications of features and/or specifications without notice.



**IPEX**  
by **alixis**

MNELLFIP210403U  
© 2021 IPEX EL0032U

